

DAVID Y. IGE
GOVERNOR OF
HAWAII



STATE OF HAWAII
DEPARTMENT OF LAND AND NATURAL RESOURCES

OFFICE OF CONSERVATION AND COASTAL LANDS
POST OFFICE BOX 621
HONOLULU, HAWAII 96809

SUZANNE D. CASE
CHAIRPERSON
BOARD OF LAND AND NATURAL RESOURCES
COMMISSION ON WATER RESOURCE MANAGEMENT

KEKOA KALUHIWA
FIRST DEPUTY

JEFFREY T. PEARSON, P.E.
DEPUTY DIRECTOR - WATER

AQUATIC RESOURCES
BOATING AND OCEAN RECREATION
BUREAU OF CONVEYANCES
COMMISSION ON WATER RESOURCE MANAGEMENT
CONSERVATION AND COASTAL LANDS
CONSERVATION AND RESOURCES ENFORCEMENT
ENGINEERING
FORESTRY AND WILDLIFE
HISTORIC PRESERVATION
KAHOOLAWE ISLAND RESERVE COMMISSION
LAND
STATE PARKS

DLNR:OCCL:NF

CDUA OA-3784

MEMORANDUM

JUL 18 2017

TO: Suzanne D. Case, Chairperson
Board of Land and Natural Resources

FROM: Samuel J. Lemmo, Administrator
Office of Conservation and Coastal Lands

A handwritten signature in black ink, appearing to read "Samuel J. Lemmo", written over a large, stylized circular scribble.

SUBJECT: Conservation District Use Permit OA-3784 for the Royal Hawaiian Groin Improvement Project Located at Waikīkī Beach, Honolulu, O'ahu, Seaward of Tax Map Keys (1) 2-6-002:005 and 006

On June 9, 2017, the Board of Land and Natural Resources approved the Conservation District Use Application OA-3784 for the Royal Hawaiian Groin Improvement Project located at Waikīkī Beach, Honolulu, O'ahu, seaward of Tax Map Keys (1) 2-6-002:005 and 006, subject to the following conditions:

1. The permittee shall comply with all applicable statutes, ordinances, rules, and regulations of the federal, state, and county governments, and applicable parts of this chapter;
2. The permittee shall comply with all applicable Department of Health administrative rules;
3. This authorization allows the Department to remediate the remaining derelict material of the existing groin after construction has been completed;
4. Before proceeding with any work authorized by the department or the board, the permittee shall submit four copies of the construction plans and specifications to the Chairperson or an authorized representative for approval for consistency with the conditions of the permit and the declarations set forth in the permit application. Three of the copies will be returned to the permittee. Plan approval by the Chairperson does not constitute approval required from other agencies;
5. The proposed work shall not be initiated prior to the completion of the State Historic Preservation Division's review to ensure compliance and satisfaction of HRS, 6E;

6. Unless otherwise authorized, any work or construction to be done on the land shall be initiated within two years of the approval of such use, in accordance with construction plans that have been signed by the Chairperson or an authorized representative, and shall be completed within three years of the approval of such use. The permittee shall notify the Department in writing when construction activity is initiated and when it is completed;
7. All representations relative to mitigation set forth in the accepted environmental assessment or impact statement for the proposed use are incorporated as conditions of the permit;
8. The permittee understands and agrees that the permit does not convey any vested right(s) or exclusive privilege;
9. Where any interference, nuisance, or harm may be caused, or hazard established by the use, the permittee shall be required to take measures to minimize or eliminate the interference, nuisance, harm, or hazard;
10. At the conclusion of work, the area shall be cleaned of all construction material and the site shall be restored to a condition acceptable to the Chairperson, including smoothing the beach to remove any tracks or indentions from the work;
11. Obstruction of public roads, trails, lateral shoreline access, and pathways shall be avoided or minimized. If obstruction is unavoidable, the permittee shall provide alternative roads, trails, lateral beach access, or pathways acceptable to the Department;
12. During construction, appropriate mitigation measures shall be implemented to minimize impacts to off-site roadways, utilities, and public facilities;
13. The permittee acknowledges that the approved work shall not hamper, impede, or otherwise limit the exercise of traditional, customary, or religious practices of native Hawaiians in the immediate area, to the extent the practices are provided for by the Constitution of the State of Hawai'i, and by Hawai'i statutory and case law;
14. Should historic remains such as artifacts, burials or concentration of charcoal be encountered during construction activities, work shall cease immediately in the vicinity of the find, and the find shall be protected from further damage. The State Historic Preservation Division shall be contacted (692-8015), which will assess the significance of the find and recommend an appropriate mitigation measure, if necessary;
15. Monitoring of the nearshore water quality shall be conducted in accordance with best management practices;
16. Work shall be conducted during calm weather periods to the most practical extent possible and no work shall occur if there is high surf or ocean conditions that will create unsafe work or beach conditions;

17. A summary project completion report to the Department shall be submitted within 90 days of completion of the project describing the status of the groin, as-built plans if any changes were made to the proposed design, what maintenance actions took place and include photographic or other quantitative evidence (beach profiles or volume calculations) of the beach conditions;
18. The permittee shall implement the proposed BMPs and monitoring and assessment plan to maintain BMPs to minimize dirt and silt from entering the ocean and the ability to contain and clean up fuel, fluid, or oil spills immediately under this authorization and immediately report any spills or other contamination(s) that occurs at the project site to the Department of Health and other appropriate agencies;
19. The permittee shall ensure that excessive siltation and turbidity is contained or otherwise minimized to the satisfaction of all appropriate agencies, through silt containment devices or barriers, or other requirements as necessary;
20. Appropriate safety and notification procedures shall be implemented. This shall include high visibility safety fencing, tape or barriers to keep people away from the active construction site and a notification to the public informing them of the project;
21. All placed material shall be free of contaminants of any kind including: excessive silt, sludge, anoxic or decaying organic matter, turbidity, temperature or abnormal water chemistry, clay, dirt, organic material, oil, floating debris, grease or foam or any other pollutant that would produce an undesirable condition to the beach or water quality;
22. The activity shall not adversely affect a federally listed threatened or endangered species or a species proposed for such designation, or destroy or adversely modify its designated critical habitat;
23. The activities shall not substantially disrupt the movement of those species of aquatic life indigenous to the area, including those species, which normally migrate through the area;
24. When the Department is notified that an individual activity deviates from the scope of work approved by this authorization or activities are adversely affecting fish or wildlife resources or their harvest, the Chairperson will direct the permittee to undertake corrective measures to address the condition affecting these resources. The permittee must suspend or modify the activity to the extent necessary to mitigate or eliminate the adverse effect;
25. No contamination of the marine or coastal environment (trash or debris) shall result from project-related activities authorized under this permit;
26. The Office of Conservation and Coastal Lands shall be notified (587-0377) in advance of the anticipated construction dates and shall be notified immediately if any changes to the scope or schedule are anticipated;
27. The permittee shall maintain safe lateral beach access during project construction;

- 28. Other terms and conditions as may be prescribed by the Chairperson;
- 29. Failure to comply with any of these conditions shall render a permit void under §13-5, as determined by the Chairperson or Board; and
- 30. Prior to implementing the project, the Chairperson will seek a second coastal engineering opinion on whether the proposed T-head groin is an appropriate design that meets the goals of the project. If the Chair upon review of the second opinion determines it is, the project shall move forward. If the Chair determines it does not, this matter shall be brought back to the Board for reconsideration. The objectives of the project are: 1) Maintain the approximate beach width of the 2012 Waikiki Beach Maintenance Project so that it can provide its intended recreational and aesthetic benefits; 2) facilitate lateral access along the shoreline; and 3) provide a first line of defense for the backshore area by maintaining a sufficiently wide beach. The Board recognizes that this project is intended to be one phase of a long-term effort to stabilize the entire Waikiki beach area, and that a planning process is underway toward that end.

Please acknowledge receipt of this approval, with the above noted conditions, in the space provided below.

Receipt acknowledged:



Applicant's Signature

Date 2/3/17

Cc: LAND
Engineering
DPP
Sea Engineering, Inc

STATE OF HAWAII
DEPARTMENT OF LAND AND NATURAL RESOURCES
OFFICE OF CONSERVATION AND COASTAL LANDS
Honolulu, Hawai'i

180-Day Exp. Date: June 11, 2017

June 9, 2017

**Board of Land and
Natural Resources
Honolulu, Hawai'i**

REGARDING: Conservation District Use Application OA-3784
Royal Hawaiian Groin Improvement Project

APPLICANT: Department of Land and Natural Resources

LANDOWNER: State of Hawai'i

LOCATION: Waikiki, Honolulu, O'ahu
Submerged Land Seaward of Tax Map Keys (1) 2-6-002:005 and 006

SUBZONE: Resource

BACKGROUND

This item was deferred at the April 28, 2017 Board of Land and Natural Resources (BLNR) meeting. The BLNR members requested additional information regarding the proposed project. Consultant Sea Engineering will discuss the analysis of the feasibility of repairing the existing structure and the impacts of T-head groins in a Power Point presentation that is attached as **Exhibit A**.

DESCRIPTION OF AREA

The project area is submerged land in the Resource subzone of the Conservation District located offshore of Waikiki Beach, along the shoreline of Māmala Bay on the south shore of the island of O'ahu. The project site is located seaward of the Sheraton Waikiki and Royal Hawaiian hotels, Tax Map Keys (1) 2-6-002:006 and 005, respectively (**Exhibits 1, 2 and 3**).

The project site extends approximately 160 feet from the seawall fronting the Sheraton Waikiki Hotel. The backshore is characterized by large resorts and high-rise condominium buildings. The resorts surrounding the project site include the Outrigger Waikiki and Moana Surfrider hotels to the east and the Halekulani, Waikiki Shore, Hale Koa, and Hilton Hawaiian Village to the west.

The Royal Hawaiian Groin forms the western boundary of the Royal Hawaiian Beach sector of Waikiki Beach, which extends 1,730 feet east to the Kūhiō Beach crib walls. A fringing fossil reef intersected by several relic stream channels extends approximately one mile offshore. The Royal Hawaiian Groin helps prevent longshore sediment transport to the west (Ewa) out of the littoral

A *as amended*
**APPROVED BY THE BOARD OF
LAND AND NATURAL RESOURCES
AT ITS MEETING HELD ON
JUN - 9 2017** *AK*

ITEM K-1

cell, although onshore-offshore transport still occurs. Wave generated longshore currents are the major factor for direction and magnitude of sand transport in the nearshore waters and on the beach. Longshore transport is mostly in the western direction, although this can shift to the eastern direction occasionally. Onshore-offshore sand transport is variable with changing wave conditions. However, there appears to be net long-term offshore transport of sand from the chronically eroding beach through the nearshore reef flat to a deeper paleo stream channel offshore (the sand source for the 2012 Waikīkī Beach Maintenance Project). High surf generates rip currents in the vicinity of the Royal Hawaiian Groin which can transport the sand offshore.

No protected species were observed in the vicinity of the project site during the September 2014 surveys. Green sea turtles, Hawaiian monk seals, and humpback whales can occur in the general vicinity. Hermatypic corals (a State protected species) occur at the project site in very low numbers.

The project site, including the waters offshore, is part of the most heavily used section of Waikīkī Beach and is used for many different ocean recreation activities including sunbathing, swimming, surfing, stand-up paddling, canoe surfing, bodyboarding, sand skimming, snorkeling, spear fishing, pole fishing, walking, wading, and metal detecting. Annual recreation events, such as canoe regattas and surf contests, are held in the project area.

BACKGROUND

Since the 1950s, more than 300,000 cubic yards of sand has been imported and placed on the beaches between Honolulu Harbor and Diamond Head¹. Following placement, much of the nourished sand is thought to have been transported seaward by nearshore dynamics². Offshore sand deposits now provide a proximal and sustainable source of sediment for beach re-nourishment³.

In 2012, the Department of Land and Natural Resources (the Department) conducted the Waikīkī Beach Maintenance Project and nourished the Royal Hawaiian-Moana Surfdrider beach sector with approximately 24,000 to 27,000 cubic yards of sand which was recovered from a nearby offshore sand field creating a beach berm with an elevation of approximately +7 feet mean sea level (MSL) and extending the dry sand area by 35 to 40 feet towards its former width in the 1980s.

The beach profile was monitored for 2.7 years by the University of Hawai‘i, School of Ocean, Earth Science and Technology, Coastal Geology Group to assess the performance of the sand nourishment effort. They concluded that overall seasonal patterns of recession and advance were found to coincide with seasonal wave conditions driving variations in rotational transport directions. Overall beach volume change since 2012 has generally been consistent with erosion rates measured from historical aerial photographs. From 1985 to 2009, the primary trend within the Royal Hawaiian Beach littoral cell was shoreline recession, with the shoreline retreating at rates up to 2.4 feet per year with an average rate of 1.5 feet. Beach monitoring following the 2012

¹ Wiegel, 2008. *Waikiki, Oahu, Hawaii, An Urban Beach Its History from a Coastal Engineering Perspective*.

² Sea Engineering, Inc. 2010. Final Environmental Assessment, Waikiki Beach Maintenance. Prepared for State of Hawaii, Department of Land and Natural Resources

³ Habel, Fletcher, Barbee, Anderson, 2016. *The influence of seasonal patterns on a beach nourishment project in a complex environment*.

Waikīkī Beach Maintenance Project showed that the beach width decreased an average of 2.9 feet over the year following completion of the project. Continued monitoring shows that after almost three years, the beach retained about 70% of the total placed volume of sand, with overall sand loss following historical rates of loss.

The existing 370-foot-long Royal Hawaiian Groin is in a deteriorated condition and is at risk of failure at any time. The groin anchors and stabilizes the middle section of Waikīkī Beach, known as the Royal Hawaiian Beach littoral cell, which extends 1,730 feet east from the Royal Hawaiian Groin to the crib wall west of Kūhiō Beach. The Royal Hawaiian Groin was originally constructed in 1927 with a large rock rubblemound apron on the western side to provide structural stability. This large rock apron no longer exists and only the first approximately 150 feet of the concrete groin wall is functional and remains above water. The remaining length of the 370-foot-long groin curves to the east and is submerged and broken apart (**Exhibit 4**). Collapse of the structure would cause the sand that is impounded on the eastern side of the groin to be released. Sediment transport in the area is typically east to west, which would allow the existing beach to drain to the west if the groin failed. The sand would then likely be lost offshore through the Halekūlani sand channel, which is considered to be a sink for nearshore sediment.

The main concern is that the landward portion of the groin is leaning to the west, severely undermined, and missing a significant portion of the inter-block concrete grout. This has resulted in large sinkholes developing on the east side of the groin that have needed to be repaired. In December 2012, approximately 45 geotextile sandbags were placed against the west side of the groin to buttress the groin and prevent it from collapsing (**Exhibit 5**). The top row of sand bags has since been displaced by wave action. This has resulted in a loss of contact with the groin, which decreases the effectiveness in stabilizing the groin. These sandbags were intended to be a temporary measure until a permanent groin improvement plan could be implemented.

PROPOSED USE

The Department is proposing to repair or replace the failing Royal Hawaiian Groin with a new stable engineered structure. The objectives of the proposed project are to maintain the beach so that it can provide its intended recreational and aesthetic benefits, facilitate lateral access along the shoreline, and provide a first line of defense for the backshore area by maintaining a sufficiently wide beach.

The Department published a Final Environmental Assessment (EA) and Finding of No Significant Impact entitled “Royal Hawaiian Groin Improvement Project” on May 2, 2016. In the Final EA, four options (**Exhibit 6**) for a new groin are proposed: 1) a new 180-foot-long rock L or T-head groin, 2) a new 280-foot-long rock L or T-head groin, 3) adaptive re-use of the existing groin as the core of a new 160-foot-long rock L-head groin, and 4) a new 160-foot-long vertical concrete wall groin. The new groin would be designed to maintain the approximate beach width of the 2012 Waikīkī Beach Maintenance Project. Since no enlargement of the beach is proposed, the 280-foot-long rock L or T-head groin option was eliminated because it is larger than necessary.

Option 1: A New 180-foot-long Rock L or T-Head Groin

A 180-foot-long rock L or T-head groin would be constructed immediately to the west of the existing groin, extending approximately 160 feet seaward from the seawall fronting the Sheraton Waikīkī Hotel (**Exhibits 7, 8 and 9**). The groin could have a L or T-head extending from the groin stem. The 180-foot-long groin would have an actual length of 230 feet (length of the stem plus two heads, as measured along the crest) and a footprint on the seafloor of 7,440 square feet. The groin stem would be made of rock rubblemound construction with side slopes of 1V:1.5H, a single layer of carefully keyed and fit 2,500 to 4,500-pound armor stone over 250 to 450-pound underlayer stone, with a concrete core wall to prevent the migration of sand through the structure. Approximately 370 cubic yards of armor stone, 425 cubic yards of underlayer stone, 15 cubic yards of leveling stone, and 60 cubic yards of pre-cast concrete would be used to construct the groin. The elevation of the stem crest would be +7 feet mean sea level (MSL) for the first 40 feet of the groin and then slope down to an elevation of +4 feet MSL for the rest of its length. The L or T-head would be constructed entirely of stone, without the concrete core wall, with a crest elevation of +4 feet MSL.

Option 2: Adaptive Re-use of the Existing Groin as the Core of a New 160-foot-long L-Head Groin

The existing groin is in a very deteriorated state, but it would be possible to construct a rock rubblemound groin structure around what remains of the existing groin (**Exhibit 10**). The existing groin would be the core wall to prevent sand migration through the structure. This option would consist of a 130-foot-long stem centered on the existing groin and a 30-foot-long L-head extending to the east. Incorporation of the existing groin would require installing a temporary barrier on the east side of the groin to hold the sand back while sand is excavated to place stone. A temporary boulder causeway would be constructed from the beach to the location of the new groin head for construction access. This would be removed as construction proceeded back towards the beach. This option would have a total length of 160 feet and a footprint of 5,990 square feet. Approximately 255 cubic yards of armor stone and 410 cubic yards of underlayer stone would be used.

Option 3: A New 160-foot-long Concrete Wall Groin

This option would be a vertical concrete wall, similar to the existing groin (**Exhibits 11 & 12**). The groin would have a 130-foot-long stem and a 30-foot-long L-head. This groin would be constructed immediately to the west of the existing groin. A temporary boulder causeway would be constructed from the beach to the location of the new groin head for construction access. This would be removed as construction proceeded back towards the beach. This option would be 160 feet long and the footprint would be 1,100 square feet. Approximately 120 cubic yards of pre-cast concrete and 35 cubic yards of marine cast-in-place "tremie" concrete would be used.

Other Alternatives Considered

The option of a 280-foot-long rock rubblemound groin was eliminated from further consideration because it is larger than necessary to maintain the approximate beach width of the 2012 Waikīkī Beach Maintenance Project.

Additional alternatives considered include maintenance of the existing groin, removal of the existing groin, no action, and other types of beach stabilization structures, such as offshore breakwaters, temporary sandbags, and geotextile tubes.

The consultant determined in the Final EA that the 180-foot-long rock rubblemound groin, Option 1, is the preferred alternative and best engineered design. This option could either have a L or T-head. An L or T-head groin would stabilize the beach and maintain the existing beach width to the east of the groin by diffracting and reducing wave energy at the shoreline, reducing the potential for rip current formation along the stem, and reducing sand transport away from the groin. The T-head would have the possible added benefit of promoting sand accretion and beach formation on the west side of the groin fronting the Sheraton Waikīkī Hotel.

General Construction Activities

A narrow pedestrian beach access is located between the Royal Hawaiian and Outrigger Hotels that provides access to the project site from Kalākaua Avenue, however the width of the access limits the size of equipment that could use it. A preliminary staging area for materials would be located at Kūhiō Beach and a second staging area for equipment storage and a limited amount of materials would be located on the beach adjacent to the existing Royal Hawaiian Groin (**Exhibit 13**). Large construction equipment and materials would have to enter at Kūhiō Beach, 1,730 feet from the project site, and move west along the beach. Stone would be delivered to the staging areas by truck early in the morning every few days or possibly daily. Construction equipment would primarily consist of a large excavator and large off-road capable trucks for stone and precast concrete delivery.

A number of site specific best management practices (BMPs) were identified to be implemented during construction including protected species and environmental monitoring, sediment and pollution control, lateral beach access control, and neighborhood comfort and safety control. No construction activities or in-water material storage would be outside of the immediate area of groin construction.

The proposed construction would occur during calm weather, low tide, and low wave action. Construction would begin when the necessary permits and approvals are obtained and a construction contract is awarded. Once all approvals are obtained, a specific construction schedule and start date would be prepared to notify approving agencies. A construction start date is currently estimated for January 2018. The construction period is estimated to be 60 days.

The following discussion is based on the proposed construction activities for the 180-foot-long L or T-head groin. Construction methods, timing, impacts, and duration would be similar for the other project alternatives identified in the FEA.

The groin stem would be constructed first on the west side of the existing groin⁴. The existing groin would remain in place until the new groin is completed. The following sequence of activities is proposed:

- 1) All loose material would be cleared fronting the seawall on the west side of the existing groin. Construction of the groin stem would begin from the west side of the existing groin. The landward portion of the stem would be temporarily overbuilt with stone, as necessary, for construction equipment and material access.
- 2) Starting from shore, all loose material would be cleared from the seafloor on the west side of the existing groin. The leveling stone bed would be placed first, followed by the precast concrete wall section, and then the core stone and armor stone would be placed up to +2.5 feet MSL. Additional armor stone would be temporarily placed on both sides of the newly constructed groin stem, as necessary, to provide for equipment access along the stem.
- 3) Continue seaward constructing the groin stem until the head section is reached, then construct the lower portion of the heads. The head section would only be constructed of stone, without the concrete core wall.
- 4) Work backward toward the shore constructing the groin to the design elevation using the temporarily placed armor stone. The top portion of the concrete core wall would be cast-in-place to obtain a uniform finished elevation. The remnants of the existing groin would be removed as construction proceeds back towards shore.

Upon construction completion, all construction materials will be removed and existing beach sand may be smoothed and redistributed in the project area, landward of the highwater mark, to restore the beach to pre-construction conditions.

SUMMARY OF COMMENTS

The Office of Conservation and Coastal Lands forwarded the subject Conservation District Use Application (CDUA) to the following agencies for review and comment: National Oceanic and Atmospheric Association; National Fish and Wildlife Service; United States Coast Guard; United States Army Corps of Engineers; City and County of Honolulu – Department of Planning and Permitting; Department of Health – Environmental Planning Office; Department of Transportation – Harbors Division; Office of Hawaiian Affairs; the Department of Land and Natural Resources Divisions of Aquatic Resources, Boating and Ocean Recreation, Oahu District Land Office, Historic Preservation Division, and Engineering; Waikīkī Neighborhood Board; Waikīkī Beach Special Improvement District Association; and Kyo-ya Hotels & Resorts, LP. In addition, the application and request for comments were sent to the Waikīkī Public Library and published in the December 23, 2016 issue of the Office of Environmental Quality Control's *Environmental Notice*.

Comments were received by the following agencies and summarized by Staff as follows:

STATE OF HAWAII

⁴ Adaptive re-use of the existing groin would involve placing boulders around the existing groin wall. The other options would require construction to be completed on the west side of the existing groin and shift the groin footprint to the west. Adaptive re-use of the existing groin would involve similar construction practices as the other alternatives.

DEPARTMENT OF HEALTH

Environmental Planning Office (EPO)

The EPO acknowledges receipt of information regarding the CDUA. EPO has prepared various informative attachments including an Environmental Health Management web application snippet of project area, Clean Water Branch Water Quality Standards Map for Oahu, and the United States Environmental Protection Agency EJSCREEN report for the project area.

Applicant's Response

Thank you for your recommendations and links to online resources for implementing sustainable and healthy design.

DEPARTMENT OF LAND AND NATURAL RESOURCES

Aquatic Resources

The Division is supportive of the project with no major objections, as construction activities will be designed to avoid and minimize impacts and no long-term impacts to the aquatic environment are anticipated. The Division would like to see BMPs addressed toward mitigation measures that include preventing any contaminants such as sediments, pollutants, petroleum products and other debris from possibly entering the aquatic environment during project activities.

Should there be any changes to the project plans, DAR requests the opportunity to review and comment on those changes.

Applicant's Response

Thank you for your comments. Mitigation measures during construction were analyzed in the Final EA and include best management practices to prevent any contaminants from entering the marine environment. We will inform you of any changes to the proposed project plans.

Boating and Ocean Recreation

No comments

Oahu District Land Office

A specific agency should be identified to be responsible for future groin maintenance.

Applicant's Response

The Department is responsible for building the proposed groin, in partnership with the Waikīkī Beach Special Improvement District Association (WBSIDA). The Department will most likely share long term maintenance responsibilities with WBSIDA.

Engineering

The rules and regulations of the National Flood Insurance Program (NFIP), Title 44 of the Code of Federal Regulations (44CFR), are in effect when development falls within a designated Flood Hazard.

The owner of the project property is responsible for researching the Flood Hazard Zone designation for the project. Flood Hazard Zone designations can be found using the Flood Insurance Rate Map, which can be accessed through the Flood Hazard Assessment Tool.

Be advised that 44CFR reflects the minimum standards as set forth by the NFIP. Local community flood ordinances may take precedence over the NFIP standards as local designations prove to be more restrictive.

Applicant's Response

Thank you for your comments. The Flood Hazard Zone designation for the area immediately inland of the project area is in Zone AE.

CITY & COUNTY OF HONOLULU

Department of Planning and Permitting

No comments.

Waikīkī Beach Special Improvement District Association

The WBSIDA agrees with the purpose and need for the project and the identified project urgency. The WBSIDA supports the 180-foot-long T-head groin alternative. The WBSIDA agrees with the supporting rationale provided in the EA for the 180-foot-long T-head groin. This option would potentially maintain the 2012 nourishment project beach configuration and width; however, it would not result in the opportunity for a significantly wider beach as part of this effort. The WBSIDA believes the 180-foot-long T-head groin is the best and most efficient economic option for the stability of Waikīkī Beach and provides the best benefit to cost ratio for possible future beach improvements of the Gray's Beach area immediately to the west.

A project benefit to cost ratio analysis, completed by the United States Army Corps of Engineers in 2002 to determine Federal interest in restoring and improving Waikīkī Beach, revealed the overall benefit to cost ratio for all Waikīkī was about 6 to 1, indicating that benefits exceed costs. The total Waikīkī Gross National product contribution to the annual Federal economy, excluding spending by mainland west coast visitors, was estimated to be \$3.3 billion.

The project is urgently needed as pointed out in the Final EA and the 180-foot-long T-head option is not only effective for stabilizing the Royal Hawaiian beach sector, but may possibly provide a slight beach enhancement to the west side of the structure. The T-head design may help stabilize the seasonal beach erosion at the Diamond Head side of the Royal Hawaiian Groin due to winter westerly wave and wind energy. The T-head design option is consistent with established engineering standards and is a proven design to stabilize dynamic shorelines.

The proposed project is consistent with existing planning studies for Waikīkī Beach improvements, and is capable of being implemented as a stand-alone project. It would also integrate well with future beach improvement projects, should they be implemented. Alternative groin design recommendations, including T-head groins have been previously assessed and recommended as possible strategies for beach improvements in Waikīkī.

The proposed sloping rock rubblemound structure provides good wave energy dissipation and minimal wave reflection back toward the offshore surf breaks. Impacts to near shore surf sites are expected to be negligible due to the design configuration, location relative to the surf sites (over 800 feet from the Populars surf break), and the wave energy dissipation of the rock structure.

Public safety concerns for the groin can be adequately managed through design, signage, and monitoring. Shoreline structures with similar public safety issues are found throughout Waikīkī and the safety issues identified for the proposed designs for the Royal Hawaiian Groin are thought to be similar or less than existing structures in the area.

Waikīkī Beach generates approximately 42% of the state's visitor industry revenue and is responsible for 8% (\$5 billion) of the Gross State Product. It has been estimated that Waikīkī Beach accounts for over \$2 billion in annual income for the local economy. However, a 2008 survey found that 12% of visitors would not return to Waikīkī due, in part, to limited beach area and resulting overcrowding. Waikīkī Beach also has tremendous cultural significance as a former playground of Hawaiian royalty and the birthplace of the sport and culture of surfing. The beaches and myriad of world-renowned surf breaks and reef ecosystem located offshore are valuable natural resources that support the culture and lifestyle of Hawai'i, and the idyllic image of Waikīkī. Preserving and maintaining these beach resources are of critical importance for the social, cultural, economic, and environmental value for Hawai'i's communities.

Applicant's Response

Thank you for your comments. We understand your support for the 180-foot-long T-head groin option, which would maintain the 2012 Waikīkī Beach Maintenance Project beach configuration, as well as possibly allow for sand accretion on the west side of the groin. We agree with you on the importance of preserving Waikīkī Beach and its significance in our economy, community, and culture.

Comments were received by the following community members and summarized by Staff as follows:

Barney McKeague

I'd like to share a story of how a couple neighbors got together and solved the problem of a beach eroding in Lanikai in the 60s. The waves were hitting the walls and the beach was gone. A small groin about 1 foot high and 1.5 feet wide was placed from the wall to where the sand dips. As the beach grew they added more groin and the beach continued to grow. When the current was running one way the sand collected and as the sand filled up it flowed over to the other side. Eventually the groin was covered over and the beach continued to grow and is still growing. We think a similar solution can be added to the groin in front of the Royal which would be small rocks sloping towards the existing wall and would surround the existing wall. It would resemble a submarine with the round bow and the round sides.

Applicant's Response

Thank you for your comments. Your suggestion seems similar to the option to re-use the existing groin as the core of a new 160-foot-long L-head groin. The existing groin is in a very deteriorated state; however, it would be possible to construct a rock rubblemound groin structure around what remains of the existing groin.

Clyde Aikau

I have been involved in Waikīkī my entire life. Learning to surf and actually working and owning a beach concession in Waikīkī from 1977 to 2006. I have been involved in all aspects of beach and water activities and am a member of the Waikīkī Advisory Board; recognized by the Department

of Land and Natural Resources. We (5 member board) certify surf instructor and canoe captain permits. I have been currently retained by the Attorney General's office to be an expert witness on a law suit against the State. I also was part of the first lifeguards hired on the North Shore along with my brother Eddie Aikau in 1967. We worked at Waimea Bay for over 10 years and never lost a life. We had no jet skis, zodiacs, helicopters. We saved lives with only swim fins and surfboard. I also have a Coast Guard Captains license to operate 100-ton vessels and have sailed on the Hōkūle'a.

I support the T-shape 180-foot breakwater. My second choice would be to only build the 180-foot breakwater with no T at the end. Evaluation of my second choice over the years may warrant the T section to be included. This proposal would protect sand from siphoning out from the actual beach on both sides of the breakwater. Yes, I expect that a beach could be immediately created to the west side of the breakwater. Consideration of the eels in the rocks should not be an issue as breakwaters at the Kaiser and Ala Moana breaks have not had these problems. Backwash and changing the surf breaks would not be an issue as the serious breaks, Queens and Canoes, have a far enough distance and it would not be affected 95% of the time.

I have been dear friends to George and Keone Downing for almost my entire life, I fully understand their position. But I hope we can all live in a world that we all can respectfully disagree. May the Lord bless Waikīkī and welcome all of its users.

Applicant's Response

Thank you for your comments. We understand your support for the 180-foot-long T or L-head groin option. The proposed project intends to maintain and stabilize Waikīkī Beach for present and future generations. The proposed project will not have a significant impact on surf breaks, as analyzed in the Final EA.

Ted Bush

My name is Ted Bush, owner of Waikīkī Beach Services (WBS). WBS operates on the beach fronting the Royal Hawaiian and Sheraton Waikīkī Hotels and is directly impacted by changes to the beach fronting both properties. I have been a beach boy in Waikīkī for 51 years and raised there for my first 18 years. I have seen many projects both good and bad in Waikīkī. It is from this perspective, an observer, waterman, and beach boy of 69 years, I share these thoughts on the proposed project.

This project aims to replace the existing Royal Hawaiian Groin with a new structure engineered to perform the same basic function as the existing structure. I support the proposed project. I believe improvements or a replacement are required to maintain the existing beach in this portion of Waikīkī. The new groin is designed to maintain the approximate beach width of the 2012 Waikīkī Beach Maintenance project. I understand no significant enlargement or addition of sand is proposed as part of this project. I agree with the purpose and need for this project and its urgency, and support the 180-foot-long "T-head" groin alternative (Option #1) in the Final Environmental Assessment (FEA) and the CDUA as the preferred alternative.

I concur with the supporting rational and engineering basis provided in the FEA for Option 1. I offer the following summary to support my position.

1. The 180-foot T-head (Option #1) is the best and most efficient option of the four designs proposed for the stability of the beach in Waikīkī.
2. I do not believe the existing groin structure is working well at stabilizing the beach and needs to be improved and brought up to modern engineering standards.
3. The "T" head design may help stabilize the seasonal beach erosion at the Diamond Head side of the Royal Hawaiian Groin due to winter westerly wave and wind energy. This has been an ongoing problem for many years and the original groin has lost its effectiveness due to the severe erosion and collapse of the portion seaward of the shoreline. This loss of height allows the seasonal surges to pass from one side of the groin to the other and subsequently cause the sand to migrate.
4. The proposed T-head design may allow for a small beach to naturally form on the Ewa side of the groin which would benefit visitors and residents who desire to recreate away from the main Royal-Hawaiian to Moana Surfrider beach area.
5. The proposed project is consistent with existing structures in Waikīkī, and is consistent with other past plans for beach improvements. It would also integrate well with future beach improvement projects should they be implemented.
6. The proposed sloping rock rubble mound structure in Option 1 provides the best wave energy dissipation and minimal wave reflection back toward the offshore surf breaks.
7. The minimized profile and scale of 180-foot T-head has a negligible impact to view planes and aesthetics on the beach relative to what is there now. This is especially true in the winter season when the beach is heavily eroded and the groin is fully exposed with lots of unsightly concrete rubble strewn around the sides of the groin.
8. Based on what information is available and my experience working and recreating in Waikīkī, I do not believe the proposed preferred alternative will have a negative impact to the surf sites or current patterns in Waikīkī.
9. The smaller 180-foot groin is to replace a 375-foot groin. This smaller footprint, its design to eliminate reflection, the existing natural reef buffer, and its distance of 800 feet from the surf sites, I believe, will prevent changes to the surf breaks.
10. The engineering of the structure is designed to retain sand on the beach and minimize offshore transport.
11. Public safety concerns for the groin can be adequately managed through design, signage and monitoring. Shoreline structures with similar public safety issues are found throughout Waikīkī and the safety issues identified for the proposed designs for the Royal Hawaiian Groin are similar if not less than existing structures in the area.

In summary, I have spent 69 years on Waikīkī Beach, most as a beach boy and waterman, and have witnessed many improvements including retaining walls, several small rock rubble groins, huge

concrete outflow groins, beach nourishments and reclamation, and saw minimal change to the surf breaks and nearshore fishery.

I marvel at the existing groin for its longevity but it is not the issue. The groin for the past 40 plus years has been slowly deteriorating and has lost its effectiveness in maintaining the beach on both sides of it. Yes, it still stands but only a shadow of its original self. Over half of it is eroded and underwater while the rest is in bad repair. It no longer blocks the westerly surges which is the main cause for the erosion on its east side and its straight concrete wall design enables powerful reflection causing erosion on its west side and rough surface conditions. I've fished every square inch of that area between Publics and Kaiser's channel, from pole, to diving, to trolling. After the tremendous amount of work done to Waikīkī during my 69 years the changes to the surf and fishery is still minimal. The fish is still verdant and plentiful and the piles of bait fish still come in to the nearshore. The biggest changes I've noticed have come from nourishments, causing some silting, thus reducing he'e, lobsters, crabs, and eels since it tends to cover the holes in the reef they need to exist. Thank you for the opportunity to provide my thoughts and share my experience on this important project.

Applicant's Response

Thank you for your comments. We understand that you, as a beach vendor located in the vicinity of the project area, will be directly affected by the proposed project and that you support the 180-foot-long T-head groin option. An improved engineered structure would better withstand coastal hazards and stabilize and maintain the existing beach. A rock rubblemound structure would have less wave reflectivity than a vertical concrete wall.

Sean Aronson

Thank you for allowing me to present written testimony on this important project. I was fortunate to attend the public hearing on March 7 and learned much about the proposed improvement of the Royal Hawaiian Groin. My name is Sean Aronson. I have lived on O'ahu for about eight years. I am currently a third-year student at the Richardson School of Law. It is my hope to work in an environmental law and policy capacity after graduation. I applaud the work you do at DLNR and appreciated your thorough explanation of the regulatory process of the project.

I am in support of the project and, after careful consideration, believe the best of the proposed structures is option 3: a new 160-foot long concrete wall groin. This option is preferable because it achieves the goal of retaining the sand fronting the Royal Hawaiian with a minimal footprint. I believe the aesthetic beauty of Waikīkī is important to locals and tourists alike and this option best preserves that beauty. I urge you to recommend option 3 to the Board of Land and Natural Resources when you file your report to them later this month.

As both a surfer and swimmer, the ocean is a vital part of my everyday life. After long days at school or work I cherish the time I have in the water and do my best not to take it for granted. The health of our ocean and beach ecosystems is something I care deeply about. Consequently, this project should be carried out in the least invasive and thoughtful manner possible in light of its potential impacts on these fragile ecosystems.

After hearing the presentation from Sea Engineering, I was tempted to support the T-head groin. According to the engineer, this option is likely to retain more sand and even potentially create a

small beach area where now there is none. But I think preserving the beauty of the area is as important as the sand retention, and option 3 best achieves this goal. I was also persuaded by the argument that a larger structure could become an attractive nuisance and perhaps introduce less than desirable activities given its broader base and overall more significant footprint than what is currently there.

I was also happy to hear that the Waikīkī Beach Special Improvement District Association will fund about half of the project. This is important because many locals at the hearing expressed their belief that this improvement will only benefit tourists. While I disagree with that sentiment, I do think getting the message out there about this non-public funding will help allay some opposition and potentially speed up the process of the project acceptance and ultimately completion of the improved groin.

In conclusion, I support option 3 for its minimal footprint and higher likelihood of retaining sand than simply repairing the existing structure. I would also like to add that the disruption caused by the construction must be mitigated as much as possible. In my opinion, the less disruption, the higher likelihood of acceptance by locals and tourists alike. Mahalo for the opportunity to express my viewpoint.

Applicant's Response

Thank you for your comments. We understand that you are in support of the 160-foot-long concrete wall groin because you believe the minimal footprint of the structure will preserve the beauty of Waikīkī and is the least invasive to the marine ecosystems. In regards to your concerns about possible undesirable activities occurring on or near the groin, the Department has been coordinating with the lifeguards to address safety concerns and mitigate public safety issues. Options include constructing a new lifeguard tower closer to the groin to provide more lifeguard presence in the area and maintain proper signage to prevent people from walking or climbing on top of the groin. The Department is in a cost share agreement with WBSIDA to share the costs of the proposed project. Construction impacts will be mitigated as much as possible. The estimate construction period is 60 days, this includes equipment set up.

H. Douglas Miki

As a long-time resident, surfer, skin-diver and fisherman who grew up but two blocks from Waikīkī Beach in the 1930's, '40s and '50s, I am writing you about my concerns on the proposed rebuilding and/or replacement of the circa 1927 Royal Hawaiian groin.

Historical Notes:

As a youngster, I attended St. Augustine School and, for a number of years, served as an altar boy in the old wood-framed St. Augustine Church. During that time, I distinctly remember the building of the then new Kapahulu Groin (the "Wall") in the very early 1950s, the creation of the man-made "beach" immediately Ewa of the Wall and the subsequent installation of 2 to 3 nearshore T Groins to stop the erosion of the man-made, imported Moloka'i sand beach. After a period of approximately 2 to 3 years, these groins were removed after failing miserably in favor of the large, sunken concrete walls that now enclose the area.

To appreciate the historical importance of Waikīkī 's surf, one only has to think back to Waikīkī 's reputation as the legendary "Playground of Kings" for Hawai'i's royalty, including the first King Kamehameha who made his home in Waikīkī until 1809, King Kamehameha V, Queen Lili'uokalani and many other royal family members. Indeed, Prince Jonah Kūhiō had a beachside house directly across the surf break known as "Queen's" where he was also known to surf and then, at the end of the day, enjoy a repast of fresh fish and his favorite brew.

The legendary "Surf at Waikīkī " is one of the primary reasons why, over the years, Waikīkī and Hawai'i have enjoyed a reputation of being a premier visitor destination. Also, as pointed out by world-class waterman and legendary Hawaiian surfer, George Downing, nowhere else in the world can one find a place where families can safely surf, swim, canoe and snorkel in a single, readily accessible beach side location. Without its surf - or with a diminished surf line, Waikīkī Beach would simply not be the same.

For radio listeners around the world, it wasn't too many years ago that broadcaster Webley Edwards would open up his popular radio broadcast, Hawai'i Calls, with the real life sounds of Waikīkī 's waves as he held his microphone down to the waves breaking on the sand in front of the Moana Hotel. I, and many others, remember well his iconic, world-wide broadcasts of Hawaiian music as we drove across snow-bound Michigan or Indiana in the dead of winter - and the opening sound of breaking waves was something I and many other listeners around the world remember so well. The sound of the surf was part of what was, as Andy Cummings wrote in his well-known song, "...the magic of Waikīkī". And for many visitors and even Hollywood stars, learning to surf and riding outrigger canoes was what helped make Waikīkī such a truly special place to be.

Waikīkī 's Surf Today:

Old-timers will tell you that - aside of the effect that the importation of sand to supplement the man-made "beaches" may have had over the years, as well as normal seasonal changes - Waikīkī's surf line has stayed essentially the same. The current proposed installation of an invasive T- Groin structure, however, may prove to have an unforeseen, negative impact on Waikīkī's traditional surf breaks.

One would have to wonder if any of the Groin's proponents as well as any of the representatives or principals of the Waikīkī Beach Special Improvement Association (WBSIDA), the Hawaiian Lodging & Tourism Association, Sea Engineering, Inc., the UH Hawai'i Sea Grant College Programs or the Hawai'i State Department of Land and Natural Resources have ever actually surfed, canoed, or snorkeled in Waikīkī on a day-in-day-out basis as visitors and the rest of us have - or are they simply reaching an arms-length, arm-chair conclusion to an oceanfront problem without regard to both history and actual user circumstances?

It would also be interesting to know just how many supporters of an extended Groin have had the opportunity to ride the inside Left Slide shoulder at Canoe Surf on a thrilling "First Break" summer's day? That stretch of surf fronting both the Moana and Royal Hawaiian hotels would be seriously altered or eliminated entirely, should an expanded, proposed Royal Hawaiian T-Groin be built.

The Future and Evaluating the Alternatives:

It is widely recognized that the visitor industry is a major component in the Hawaiian economy. As such, it should be supported by the community at large. Such support, however, should not come at the expense of an integral, if apparently, less-appreciated part of what has made and continues to make Waikīkī a very special place - its surf. A disregard of its role toward creating the very legend of Waikīkī in favor of quick or easy fixes or to -- as a proponent once bluntly and blatantly stated in a public hearing for a previous Waikīkī sand erosion project "... to mainly protect our hotel occupancy levels and hotel lobby shop sales to visitors!" - would prove to be unfortunate and a loss for everyone.

As pointed out in recent public testimony, the installation of a 180 foot or extended Groin in any shape or form can be expected - despite arm-chair assurances to the contrary - to seriously and adversely affect, in real life terms, the traditional surf zones in Waikīkī. Also, as pointed out, there are questions as to an extended Groin's appearance, safety and the fact that it would prove hospitable to ocean predators, such as eels. Also, not addressed are questions as to how children and visitors are to be discouraged on an ongoing basis from climbing up onto what will certainly be entirely slippery boulder surfaces; Who is to maintain such a structure and Who is to be held liable for injuries incurred by people climbing the structure?

In evaluating the possible alternatives for the repair and/or replacement of the existing 1927 Royal Hawaiian Groin, it appears that Save Our Surf's position of having the existing groin repaired or replicated in place would be the best of all alternatives, cost-wise and otherwise. Failing that, the second alternative would be to put in place a modified wall groin with a smaller expanse and without any large, unsightly and decidedly "unsafe" boulders.

Thank you for your consideration of my thoughts and for your reflecting on the area's truly unique history as well as the implications of making any changes - inadvertent or otherwise - that could negatively impact Waikīkī 's surf zones. I am not a member of Save Our Surf nor affiliated with any organization already speaking on this matter.

Applicant's Response

Thank you for your comments. The existing groin is 370 feet long, curves towards the east, and extends 250 feet from the shore. All the options we are proposing extend much less than the existing groin. Rock rubblemound groins have very little wave reflectivity and will not be reflecting waves back towards the surf breaks. A concrete wall groin is more likely to have an impact on surf breaks and decrease the stability of beach resources due to its high wave energy reflectivity. A new groin would be located well landward of the nearby surf breaks, with the head about 800 feet landward of the Populars surf break riding zone. The options that extends the farthest from shore, the 180-foot-long rock rubblemound T-head groin option, extends 160 feet seaward from the shore. We are cognizant of the importance of surf sites to the community and culture and have designed the options so they will not result in a change to the surf breaks. An analysis of the effects of the proposed project on surfing can be found in the Final EA.

The Department has been coordinating with the lifeguards to address safety concerns and mitigate public safety issues. Options include constructing a new lifeguard tower closer to the groin to provide more lifeguard presence in the area and maintain proper signage to prevent people from walking or climbing on top of the groin. We have no evidence that

constructing a rock rubblemound structure will cause an increased number of eels in the area.

The Department is responsible for building the proposed groin, in partnership with the WBSIDA. The Department will most likely share long term maintenance responsibilities with WBSIDA.

Stuart Coleman, Hawaii Manager of Surfrider Foundation

On behalf of the Surfrider Foundation Hawai'i, I respectfully offer comments on the proposed improvements to the Royal Hawaiian Groin. The project aims to repair or replace the existing Royal Hawaiian Groin with a new structure engineered to perform the same basic function as the existing structure. Surfrider supports making critical improvements to the Royal Hawaiian Groin to ensure that the beach sand in Waikīkī remains on the beach in a stable formation. Improvements to this structure are required to prevent a possible failure of the existing structure and maintain the existing beach in this portion of Waikīkī. The new groin is designed to maintain the approximate beach width of the 2012 Waikīkī Beach Maintenance project. Surfrider understands no significant enlargement or addition of sand is proposed as part of this project. Surfrider agrees with the purpose and need for the project and the identified project urgency. We support the 180-foot-long "T-head" groin alternative (Option #1) in the Final Environmental Assessment (FEA) as the preferred alternative, but we would also support rebuilding the current structure if that proves to be a less expensive and effective solution.

After reviewing the information and studies made available, Surfrider feels Option 1 provides the maximum protection of the beach at the Royal Hawaiian and will be most effective at stabilizing the existing beach. The Surfrider agrees with the supporting rational and engineering basis provided in the FEA for Option 1. We offer the following summary to support our position to make improvements including the 180 foot "T-head" option:

1. The 180-foot T-head (Option #1) is the best and most efficient option for the stability of the beach in Waikīkī. We believe this option will be most effective at stabilizing the beach at the Royal Hawaiian. Some of our members worry the Royal groin is not working well at stabilizing the beach.
2. The "T" head design may help stabilize the seasonal beach erosion at the Diamond Head side of the Royal Hawaiian Groin due to winter westerly wave and wind energy.
3. The proposed sloping rock rubble mound structure in Option 1 seems to provide the best wave energy dissipation and minimal wave reflection back toward the offshore surf breaks. This is evidenced by the wave model results provided in the Final Environmental Assessment
4. The minimized profile and scale of 180-foot T-head has a negligible impact to view planes and aesthetics on the beach relative to what is there now. This is especially true in the winter season when the beach is heavily eroded and the groin is fully exposed with lots of unsightly concrete rubble strewn around the sides of the groin.
5. Based on what information is available Surfrider does NOT believe ANY of the proposed alternatives will have a negative impact to the surf sites or current patterns in Waikīkī. The location of the groin relative to the surf sites (over 1,500 feet from the Populars surf break and over 1,000 feet from the Canoes surf break) and the wave energy dissipation of the

rock structure should prevent change to the existing surf breaks which are located on reefs that are several feet above the elevation of the sand bed.

6. According to the Final Environmental Assessment for this project, the smaller reformed waves at Baby Royals and Inside Canoes (650ft and 1000ft from the groin respectively) are not expected to have appreciable sand transport changes or be significantly altered due to any of the 4 options provided.
7. The engineering of the structure is specifically designed to retain sand on the beach and minimize offshore transport.
8. Although we have public safety concerns about people climbing or getting caught in the groin, we trust that they can be adequately managed through design, signage and monitoring. Shoreline structures with similar public safety issues are found throughout Waikīkī and the safety issues identified for the proposed designs for the Royal Hawaiian Groin are similar and even less than existing structures in the area.

Applicant's Response

Thank you for your comments. We understand your support for the 180-foot-long T-head option because you believe it would be the most effective at stabilizing the existing beach and have minimal wave reflection back toward offshore surf breaks. We agree with your conclusion that none of the proposed alternatives will have a negative impact to surf sites. The Department has been coordinating with the lifeguards to address safety concerns and mitigate public safety issues. Options include constructing a new lifeguard tower closer to the groin to provide more lifeguard presence in the area and maintain proper signage to prevent people from walking or climbing on top of the groin.

A Public Hearing for the project was held at the Waikīkī Community Center on March 7, 2017 to inform the public of the proposal and to solicit public input. The meeting was held at 6:00 p.m. and ended before 8:00 p.m. It was attended by approximately 50 people. The Department and the consultant summarized the proposal. Several members of the public testified generally in opposition to the proposal. Their comments and concerns are summarized below.

PUBLIC HEARING TESTIMONY

1. Tek Yoon – Concerned that sand being placed in Waikīkī for the visitor industry has killed the reef and changed the surf breaks.
2. Tim Garry – In favor of replacing the groin exactly the way it is. Even though it is deteriorating, it has worked for 80 years. Feels that whenever you place a structure in the ocean, it impedes the sand from moving around the island. In an effort to compromise with the hotels, the structure should be replaced with one exactly like it.
3. Ellen Sofio – Concerned we are losing Hawai'i, environmentally, scenically, visually. It's being continuously eroded. The groin should be replaced as close to the existing structure as possible. Should use basalt rock as much as possible, instead of cement. Basalt rock would be a better habitat for marine life.
4. Dave Moskowitz – Questioned where figures were obtained on how much we would lose in revenue and jobs if Waikīkī Beach was lost. Believes that a greater portion of the project cost should be paid for by visitor industry, and not the residents. The project should be a compromise that suits everybody.

5. Robert Peters – Concerned that there might not be enough input from the locals and about the project effects on surfing. Believes surfing is the beauty of Waikīkī, not the beaches or the tourists. Wants Waikīkī left alone. Wants to know if we made announcements of past meetings, inviting the public to provide input before making decisions.
6. Ernie Foster – Iroquois Point is not a similar situation to Waikīkī. Believes that the sand would still be there without the groins. In Waikīkī, the sand will always move away from the beach. Believes the groins weren't built because the locals requested them, but because of rich people coming to Waikīkī. Believes the visitor industry should be paying for it, not the taxpayers. Concerned that Waikīkī will be underwater in the future so why build a new groin. Wants to know how the proposed project is going to benefit anyone other than the hotels.
7. Mike Sur – Part-time commercial fisherman. Concerned that if you change the blueprint of the bottom of Waikīkī, it might affect our fisheries offshore. Indicated that he has caught thousands of pounds of akule and feeds thousands of people. Wants to know if anyone has completed any studies on how this proposal will affect the fisheries.
8. Matt Abe – Indicated that growing up, he learned how to surf in Waikīkī and it is dear to all who have learned to surf there. Concerned that if you were to change the ocean floor, albeit ever so slightly, it'll change the surf breaks that generations of surfers, paddlers, and swimmers have grown up with. Said that natural causes move the sand, but it naturally moves back. Installing man-made structures changes everything. Said that he had a problem with the aesthetic value of the T-head groin and questioned whether tourists would like to see rocks sticking out into the ocean shaped in the letter "T." Believes that if it's not broke, why fix it. He believes it's best to reevaluate the existing groin to see if there's a way to repair or replace it to its original form. Asked who would be responsible for maintaining the T-head groin. Noted that if you look at other surf spots, such as Rockpiles, Kaisers, and Bowls, there are a lot of boulders that tourists and locals walk out on and slip. There are a lot of crevices and litter, such as fish hooks, that gets caught in the crevices. Any change in Hawai'i takes three, four, or five times to undo.
9. Jim Hayes – Believes that everyone views Waikīkī at a different point in time. He said he learned to surf there, and still does. He is teaching his son how to surf there. He and his wife enjoy that there is a beach there now and they can thank the existing groin for the beach. He remembers it as a good surf spot with the groin and beach there. He said his son remembers it as a wonderful beach to play on. He said he sees the T-head groin as being an improvement from an aesthetic point of view and he hopes that it'll maintain the sand that's there and even possibly allow for sand on the Ewa side of the groin. It seems like a wasted opportunity, if there's a possibility you could continue to walk on sand on the Ewa side of the wall. He said he reviewed the Environmental Assessment for the proposed project and believes the DLNR did a thorough analysis of possible impacts. His main point was that Waikīkī is what it is. If we can keep the sand there and maybe improve it, more tourists would be willing to stay there and maybe even more locals could enjoy the beach, too.
10. Brian Shimokawa – Said he was a founding member of Save Our Kakaako. Questioned where was all the input of what can be done before the State came up with these plans. Noted that the existing groin is going on 90 years, with the advancement of technology believed that we could keep the groin as is. Believes that once you fight with nature, it's a losing battle. Once you build one groin, you're going to have to build another and then another. Let nature do its thing.

11. Keone Downing – Said that he believes Save Our Surf must take care of Māmala Bay and keep it safe for visitors and locals, alike. Noted that Waikīkī is special. It’s a major economic engine for Hawai‘i and must be treated appropriately. Protection and safety of its beach, as well as its surf, has always been a top priority for Save our Surf. He believed that the first choice is to restore the groin if can. Second, if it can’t be fixed to replace it in the same footprint with the same concrete that is done now. And third, if anything, believes that the footprint should be reduced. The sand has been going out to sea. Maybe by reducing the footprint the sand will flow down westerly and create a beach at different seasonal times.

Staff listened to the public testimony and took notes (meeting was also recorded). Most of the people testifying had concerns or were opposed to a T-head rock rubblemound groin, although at least two people appeared to support the project. Staff tried to address some of the questions at the end of the meeting. In addition, several written comments were received on the EA and CDUA application. Staff has summarized all major concerns or questions received on the project and provides a brief response for each one. More information and responses to comments received on the EA can be reviewed in the Final EA document.

1. Who is responsible for the groin after it is built?

The Department is responsible for building the proposed groin, in partnership with the WBSIDA. The Department will most likely share long term maintenance responsibilities with WBSIDA.

2. Did the State consider the aesthetics of the proposed groin?

Aesthetics is a subjective issue. We recognize that constructing a groin that differs from the existing groin may seem offensive to some people and not offensive to others.

3. What impacts will the proposed project have on fisheries?

Potential impacts of the proposed project on shoreline processes, biological effects, and effects on endangered species were analyzed in the Final EA. Water quality and biological surveys were completed by AECOS, Inc and can be found in the appendix of the Final EA. The project is not anticipated to have any impact to fisheries as any one of the alternatives discussed in the Final EA either replace what is already there or only slightly increases or moves the footprint of the structure that is there. The project does not change the function or purpose of the groin, nor the size of the beach that it is intended to stabilize.

4. Were there any previous hearings to gather public input for the proposed project?

There were no prior “public hearings.” The public hearing held on March 7, 2017 was held as part of the CDUA process to gather community input and testimony on the proposed project. Notice of the CDUA was published in the December 23, 2016 issue of the Environmental Notice and the public could submit comments regarding the CDUA. The Draft EA was published with a 30-day comment period in the January 3, 2016 issue of the Environmental Notice. Prior to the publication of the Final EA, in February and March 2016, the Department

and WBSIDA held a public informational briefing, a meeting with the City and County of Honolulu lifeguards, a meeting with hotel industry representatives, and presented at a Waikiki Neighborhood Board meeting to gather community input to include in the Final EA. Notices of all public meetings and comment periods were provided. A decision has not been made. The four options will be presented to the BLNR to decide which option should be implemented.

5. How will it impact surfing?

The existing groin is 370 feet long, curves towards the east, and extends 250 feet from the shore. All the options we are proposing extend much less than the existing groin. Rock rubblemound groins have very little wave reflectivity and will not be reflecting waves back towards the surf breaks. A new groin would be located well landward of the nearby surf breaks, with the head about 800 feet landward of the Populars surf break riding zone. The rock rubblemound T-head groin option extends 160 feet seaward from shore. We are cognizant of the importance of surf sites to the community and culture and have designed the options so they will not result in a change to the surf breaks. An analysis of the effects of the proposed project on surfing can be found in the Final EA.

6. What about the impact of sand when sedimentation covers the reef and the habitat for fish is gone?

No sand is being placed on the beach with the proposed project. The proposed project is to improve the existing Royal Hawaiian Groin by replacing it with a more stable, engineered groin that will maintain the shoreline established during the 2012 Waikiki Beach Maintenance Project. There will be some sand turbidity generated from project construction, but this will be maintained with best management practices and within Department of Health water quality guidelines.

7. Has a shoreline certification been done? If sand accretes on the west side of the groin, would a new shoreline certification be completed?

A shoreline certification was not obtained for the proposed project. We do not intend to certify the shoreline should sand accrete on the west side of the groin. The shoreline follows the seaward face of the Royal Hawaiian/Sheraton Waikiki Seawall. The project does not change the location of the shoreline.

8. When was last nourishment? How many groins did you remove at Kūhiō Beach? When you placed sand, you did it from Kūhiō to Royal Hawaiian? And all that sand has disappeared so why would we believe the engineers that are saying this groin option would work?

In 2012, the State completed the Waikiki Beach Maintenance Project from Kūhiō Beach to the Royal Hawaiian Groin. Approximately 24,000 cubic yards of sand was placed on the beach, extending the dry sand area by 35 to 40 feet in width. Two sandbag groins were removed at Kūhiō Beach. Continued monitoring of the 2012 beach nourishment shows that after 2.7 years the beach retained much of the total placed volume, with overall sand loss in the order of the historical rate of loss, and the loss of roughly half of the original placed width.

9. How long will construction take?

Construction is anticipated to take approximately 60 days. This estimate includes equipment set up.

10. Is the price guaranteed?

The prices shown in the Final EA are preliminary estimates and are subject to inflation and project changes.

11. Has the decision already been made on which option will be built?

A decision has not been made for the proposed project. The four options will be presented to the BLNR and staff will recommend one of the options. The Department hired Sea Engineering, Inc. to design options for the proposed project and they provided us with what they believe is the best engineered solution to this situation. Sea Engineering Inc. chose the rock rubblemound T-head groin option as the preferred alternative because they believe it'll serve the purpose of retaining the sand and have the best outcome. Typically, in an EA, a preferred alternative is selected for the permitting process. Public comments will be provided to the BLNR.

12. Has a contractor been selected?

A contractor has not been selected. The bidding process for contractor selection will begin once permits are obtained.

13. Has anyone looked at bringing materials in by barge rather than staging materials at Kūhiō Beach?

The matter was researched, but the nearshore waters in Waikīkī are too shallow to support barges.

14. Could the groin be fixed through an emergency permit to prevent it from failing while pursuing permitting the different options?

The Department accomplished an emergency repair in 2012, in which 3,000 pound sandbags were stacked along the west side of the groin to buttress it and help prevent it from toppling over. The sandbags are currently in a deteriorated condition and the entire top row of bags has been displaced. These sandbags were installed as a temporary measure until a permanent improvement plan could be implemented.

15. Can you just fix the groin, replace it as it is, or reduce the footprint?

The existing groin cannot be fixed and would minimally need to be replaced or buttressed. Placing a smaller groin in its place is not advisable as it would not retain the current configuration and sand volume of Royal Hawaiian Beach and sand would likely be lost to the west. The Department has evaluated four alternatives, including like-to-like replacement, and

believes that a rock rubblemound structure would be the most optimal engineering solution and believes that such a structure is preferable to a flat wall.

16. Where was data on visitor revenues obtained from?

Staff addressed this concern at the public hearing by noting the existence of a report titled "Economic Impact Analysis of the Potential Erosion of Waikiki Beach" completed by Hospitality Advisors, LLC for the Waikiki Improvement Association in 2008. The report is currently being updated and a new report is expected to be released in summer 2017 (Department staff forwarded the report to the commenter following the public hearing).

17. Shouldn't the visitor industry pay for this?

The Department has a cost share agreement with WBSIDA for the proposed project. The proposed project will help maintain Waikiki Beach which will provide an erodible buffer for the highly developed backshore area. Waikiki Beach is utilized by both visitors and locals.

18. Has anyone discussed the proposed project with the lifeguards? How will they keep people from climbing on the groin?

The Department has been coordinating with the lifeguards to address safety concerns and mitigate public safety issues. Options include constructing a new lifeguard tower closer to the groin to provide more lifeguard presence in the area and maintain proper signage to prevent people from walking or climbing on top of the groin.

ANALYSIS

After reviewing the application, by correspondence dated December 13, 2016, the Department has found that:

1. The proposed use is an identified land use in the Resource subzone of the Conservation District, pursuant to Hawai'i Administrative Rules (HAR) §13-5-22, P-15 Shoreline Erosion Control *Seawall, revetment, groin, or other coastal erosion control structure or device, including sand placement, to control erosion of land or inland area by coastal waters, provided that the applicant shows that (1) the applicant would be deprived of all reasonable use of the land or building without the permit; (2) the use would not adversely affect beach processes or lateral public access along the shoreline, without adequately compensating the State for its loss; or (3) public facilities (e.g., public roads) critical to public health, safety, and welfare would be severely damaged or destroyed without a shoreline erosion control structure, and there are no reasonable alternatives (e.g., relocation). Requires a shoreline certification.* Please be advised, however, that this finding does not constitute approval of the proposal;
2. Pursuant to §13-5-40(a) (4), HAR, a Public Hearing is required;
3. In conformance with Chapter 343, Hawai'i Revised Statutes (HRS), as amended, and Chapter 11-200, HAR, the Department determined a finding of No Significant Impact for

the proposed project. The Final EA was published in the May 23, 2016 issue of the *Environmental Notice*; and

4. The project area does not lie within the Special Management Area.

A public hearing was held on March 7, 2017 in Waikīkī, O'ahu to receive public testimony. Approximately 50 individuals were in attendance. Comments and concerns expressed at the public hearing are listed under Summary of Comments.

Evaluation Criteria

The following discussion evaluates the merits of the proposed land use by applying the criteria established in HAR §13-5-30:

- 1) *The proposed use is consistent with the purpose of the Conservation District.*

The purpose of the Conservation District is to conserve, protect and preserve the important natural and cultural resources of the State through appropriate management and use to promote their long-term sustainability and the public health, safety, and welfare.

The proposed use should not conflict with the above objectives as the project is expected to maintain the beach width of the 2012 Waikīkī Beach Maintenance Project and would not adversely affect beach processes.

- 2) *The proposed land use is consistent with the objectives of the subzone of the land on which the use will occur.*

The objective of the Resource Subzone is to ensure with proper management the sustainable use of the natural resources of those areas. Staff believes that the proposed use sustains the public beach at the site. Without the proposed action, the Royal Hawaiian Groin beach sector may be lost and contribute to the decline of water quality, beach habitat, and public use.

- 3) *The proposed land use is consistent with several of the provisions and guidelines contained in Chapter 205A, HRS entitled "Coastal Zone Management", where applicable.*

Staff believes the proposed use is consistent with several of the provisions and guidelines contained in Chapter 205A, HRS, including:

Recreational Resources: The proposed project would help stabilize and maintain the approximate beach width of the 2012 Waikīkī Beach Maintenance Project, have a positive effect on public access, and continue to provide coastal recreational opportunities;

Scenic and Open Space Resources: Waikīkī is densely developed with limited open space. The beach is the largest area of open space in Waikīkī and the proposed project would preserve and maintain the open space resource;

Historic Resources: The groin itself is potentially eligible for inclusion within the Hawai'i and National Register of Historic Places under Criteria C, for engineering, at the local level of significance. No archaeological or cultural resources are expected in the project site; however, if archaeological or cultural resources are found during construction, construction will be halted and the applicant will be directed to contact the State Historic Preservation Division (SHPD) immediately;

Marine and Coastal ecosystems: BMPs will be deployed and maintained throughout the construction period to avoid and minimize impacts to the marine environment. The proposed groin would be placed on nearshore sand and rubble bottom, thus there will be no significant loss of marine habitat;

Economic Uses: Staff believes the proposed project preserves the economic value of the natural resources in Waikīkī by maintaining and stabilizing the beach; and

Coastal Hazards: The proposed project reduces coastal hazards to the highly developed backshore area by maintaining the beach width and improving the stability of the beach;

- 4) *The proposed land use will not cause substantial adverse impact to existing natural resources within the surrounding area, community or region.*

The proposed use involves improving the existing groin by constructing a stable, engineered groin to reduce the likelihood of failure and beach loss. The proposed use would improve long-term beach stability for Waikīkī. No long-term environmental impacts are expected from the proposed use.

- 5) *The proposed land use, including buildings, structures and facilities, shall be compatible with the locality and surrounding areas, appropriate to the physical conditions and capabilities of the specific parcel or parcels.*

The proposed use has been designed by an experienced coastal engineering firm based upon studies of local wave magnitude and direction; weather conditions including tides, currents, wind, and waves; regional and local beach erosion history; and assessments of similar rock groins. The proposed use is designed to be compatible with the physical conditions and capabilities of the area.

- 6) *The existing physical and environmental aspects of the land, such as natural beauty and open space characteristics, will be preserved or improved upon, whichever is applicable.*

Staff believes that the proposed use attempts to preserve and improve the beach resource and open space characteristics. Tall buildings dominate the backshore area of Waikīkī Beach with limited open space. Waikīkī Beach itself is the largest expanse of open space. The proposed use attempts to preserve the open space by improving beach stability.

- 7) *Subdivision of land will not be utilized to increase the intensity of land uses in the Conservation District.*

No subdivision of land is proposed.

- 8) *The proposed land use will not be materially detrimental to the public health, safety and welfare.*

The purpose of the proposed use is to stabilize and preserve Waikīkī Beach which would provide an erosion buffer to the backshore infrastructure. Staff believes that the proposed use will not be materially detrimental to the public health, safety, and welfare.

CULTURAL AND HISTORICAL IMPACT REVIEW

Identity and scope of cultural, historical, and natural resources in which traditional and customary native Hawaiian rights are exercised.

The project site is part of the most heavily used section of Waikīkī Beach. No cultural artifacts or burial remains have been observed during periods of substantial beach loss nor are any expected to be present on an active beach that seasonally erodes and accretes. There will be no construction or excavation of the backshore area that may contain physical remains. Staging areas will be established near Kūhiō Beach and next to the Royal Hawaiian Groin these are in areas recently nourished during the 2012 Waikīkī Beach Maintenance Project. Construction of the groin would take place in the water and would not involve modification of soft deposits that may contain cultural artifacts or burials. The groin itself is potentially eligible for inclusion within the Hawai'i and National Register of Historic Places under Criteria C, for engineering, at the local level of significance.

There are native Hawaiian legends and practices commonly associated with Waikīkī and its surroundings. Traditional cultural practices that take place in the project vicinity include fishing, reflection, shoreline access, and ocean recreational activities, such as swimming and surfing, although no specific practice has been identified in association with this project. During the processing of this application, no comments were received from native practitioners, the Office of Hawaiian Affairs, or the SHPD. A condition will be included with this permit that the proposed work shall not be initiated prior to the completion of the State Historic Preservation Division's review to ensure compliance and satisfaction of HRS, 6E.

The extent to which those resources, including traditional and customary native Hawaiian rights, will be effected or impacted by the proposed action

During construction, portions of the beach may be inaccessible to the public and temporarily disrupt traditional and customary practices. Upon completion, the project would not curtail these activities. To the extent to which traditional and customary native Hawaiian rights may be exercised, the proposed action would not appear to affect traditional Hawaiian rights since the Royal Hawaiian Groin is a contemporary structure, the purpose of the project is to repair or replace an existing structure, and the work is temporary and will not change the nature or function of the beach.

What feasible action, if any, could be taken by the Board of Land and Natural Resources in regards to the application to reasonably protect native Hawaiian rights?

As noted, it does not appear that the project effects native Hawaiian rights. However, the permit will include a standard condition that “the permittee acknowledges that the approved work shall not hamper, impede, or otherwise limit the exercise of traditional, customary, or religious practices of native Hawaiians in the immediate area, to the extent the practices are provided for by the Constitution of the State of Hawai‘i, and by Hawai‘i statutory and case law.”

The permit will also include a condition that states “Should historic remains such as artifacts, burials or concentration of charcoal be encountered during construction activities, work shall cease immediately in the vicinity of the find, and the find shall be protected from further damage. The SHPD shall be contacted (692-8015), which will assess the significance of the find and recommend an appropriate mitigation measure, if necessary.”

DISCUSSION

Nestled between the majesty of Diamond Head (Lē‘ahi), the base of the verdant Ko‘olau Mountains, and the beautiful Māmala Bay, is the jewel called Waikīkī (spouting water). Perhaps Hawai‘i’s greatest legacy exists on a stretch of shoreline known to the world as Waikīkī Beach. It is likely the most famous beach in the world, certainly within the United States, so famously popularized by Duke Kahanamoku. The beach is everything and anything to Hawai‘i’s people and its visitors. It is a place of recreation, meditation, and commerce. It is the transitional point from land to sea, where people, nature, and even the city, all come together. Its importance is clear.

The Waikīkī shore today attracts more than four million visitors per year and is responsible for over eight percent of the Gross State Product and almost eight percent of all civilian jobs statewide. Real estate values in Waikīkī are estimated to be in the several billions of dollars. On any given day, there are roughly as many visitors as there are residents squeezed into an area of about two square miles. Today, Waikīkī is a multicultural, urban beach carefully placed between the Ko‘olau mountain range and the warm waters of the Pacific at Māmala Bay.

Over the past 100 years, Waikīkī Beach and its surrounding marine and terrestrial land have been transformed. The changes are astonishing. Old photographs, engineering records, and Hawaiian ‘ōlelo (story) do not belie man’s manipulative tinkering in this once pristine coastal marshland. Waikīkī was once a splendid ahupua‘a (watershed) in the most classical sense where mountains, valleys, streams, marshes, the beach, and offshore reefs formed a large interconnected ecosystem that provided sustenance and enjoyment for its ancient inhabitants. However, Waikīkī has been completely transformed in modern times. Sand nourishment, reef dredging, groin construction, seawalls, the construction of the Ala Wai Canal, tall buildings, and dozens of other coastal engineering projects have altered Waikīkī forever. Ironically and sadly, one of Waikīkī’s most fascinating and important legacies is its engineered past.

Few people realize that much of the Waikīkī shoreline was lined with seawalls in the early part of the 20th century in response to beach erosion caused by sand mining and the placement of buildings and public infrastructure too close to the water. Few people know of the 1928 Waikīkī Beach Reclamation Agreement that set the stage for large-scale beach nourishment in Waikīkī, resulting in at least 307,400 cubic yards of sand being imported to Waikīkī, sand that was taken

from other Hawaiian beaches. Few people know of the battles waged between the government and the group Save Our Surf over efforts to stop coastal engineering projects.

The first major step to repair the badly damaged Waikīkī shoreline, involved the preparation of a report by the Engineering Association of Hawai‘i, Committee on Waikīkī Beach Improvements in 1927 (under the auspices of the Board of Harbor Commissioners, Territory of Hawai‘i). The report discussed issues such as public access, elimination of coral in bathing areas, and proposed beach fill. It is likely that this report also formed the basis for the 1928 Waikīkī Beach Reclamation Agreement, which consisted of various agreements between the Territory of Hawai‘i and the abutting private landowners. The 1928 Agreement set the stage for large-scale beach nourishment projects in Waikīkī by first eliminating accretion rights vested to the abutting private property owners, and then deeding these areas back to the abutting owners, subject to the private property owners allowing a 75-foot wide public access easement on the most seaward portion of the newly restored beach.

Although there was a substantial beach restoration project at Kūhiō Beach in 1938-39, beach nourishment projects only began in earnest in the 1950s. We have listed sand nourishment projects by year and volume to the best of our ability. These numbers are largely based on a report by Dr. Robert L. Wiegel, “Waikīkī, Oahu, Hawai‘i, An Urban Beach, Its History from A Coastal Engineering Perspective,” dated November, 2002.

1939	7,000 cubic yards at Kūhiō Beach
1951-57	130-160,000 cubic yards at Kūhiō Beach, Queens Surf Beach, and Kapi‘olani Beach Park
1959	19,000 cubic yards at Kūhiō Beach
1965	6,000 cubic yards at Outrigger Canoe Club
1970	82,000 cubic yards at Fort DeRussey Beach
1972	12,000 cubic yards at Kūhiō Beach
1975	16,000 cubic yards at Fort DeRussey Beach
2003	1,400 cubic yards at Kūhiō Beach
2007	10,000 cubic yards at Kūhiō Beach
2012	24,000 cubic yards at Waikīkī Beach
Total	307,400-337,400 cubic yards

This historical overview confirms that Waikīkī has undergone significant changes over the past century. King Kamehameha the Great stayed in Waikīkī after conquering Maui, O‘ahu, and Hawai‘i islands. Subsequent rulers of the islands also resided in Waikīkī, such as David Kalākaua, Hawai‘i’s last true king. During this time, Waikīkī was a rich marshland with streams, springs, and a beautiful fringing beach, with perfect surfing waves offshore. However, after the death of King Kamehameha the Great and the subsequent demise of the Hawaiian feudal land system, which all culminated in the Great Māhele enacted in 1848, much of Hawai‘i’s land was sold to foreign interests. Subsequent years of uncoordinated development forever changed Waikīkī and resulted in the loss of the beach, marshlands, and streams. Following World War II, hundreds of thousands of yards of beach sand was imported to Waikīkī Beach in an attempt to restore what had been lost and to promote the new tourist industry, yet there remained concerns about sand importation and potential effects on Waikīkī’s famous surfing waves.

After a long respite of major beach management actions, a beach nourishment project was completed in the spring of 2012 along the Royal Hawaiian Beach segment of Waikīkī on the island of O‘ahu, Hawai‘i. This was the largest nourishment effort to take place in 40 years within Waikīkī. The nourishment was completed at a cost of \$2.9 million, funded by a joint public-private partnership including contributions from the State of Hawai‘i, the Hawai‘i Tourism Authority, and Kyo-ya Resorts. The Department, the trustee of Hawai‘i’s beaches and coastal lands, oversaw the project. The objectives of the nourishment were to restore the aesthetics and recreational usage of the beach in response to long-term chronic erosion and to promote lateral access along the shore (Environmental Assessment for Waikīkī Beach Maintenance, 2010).

As part of the nourishment project, the following components were proposed and completed:

- Recovery and dewatering of 18,350 cubic meters (24,000-27,000 cubic yards) of sand from sources located approximately 0.6 kilometers offshore of the nourishment site.
- Emplacement of sand along a 520 meter (1,700 foot) segment of coastline with the goal of increasing the beach width by an average of 11.2 meters (37 feet), restoring the beach width to the extent of the 1985 shoreline and not beyond.
- Increase of beach area above the high tide line by 6,040 square meters (7,900 square yards).
- Removal of two dilapidated sand bag groin structures located near the easternmost end of the project area.

The University of Hawai‘i, School of Ocean, Earth Science and Technology monitored project performance for almost three years. They concluded that overall seasonal patterns of recession and advance were found to coincide with seasonal and wave conditions and variations in rotational transport directions. Overall beach volume change is generally consistent with historical rates. From 1985 to 2009, the primary trend within the Royal Hawaiian littoral cell was shoreline recession with the shoreline retreating at rates up to 2.4 feet per year with an average rate of 1.5 feet. Beach monitoring following the 2012 Waikīkī Beach Maintenance Project showed that the beach width decreased an average of 2.9 feet over the year following completion of the project. Continued monitoring shows that after almost three years, the beach retained approximately 70% of the total placed volume of sand, with overall sand loss following historical rates of loss.

The proposed Royal Hawaiian Groin improvement project is not the first or last effort of its type in Waikīkī. The Department in partnership with the WBSIDA is initiating a major reconnaissance effort toward a repair of the Waikīkī shoreline named *Ho‘omau ‘O Waikīkī Kahakai* (Waikīkī Beach Renews Itself). Much of the existing shoreline, including the Royal Hawaiian Groin, is 50 to 100 years old. It is time to look at the Waikīkī shoreline to begin preparing it for the next 100 years to ensure that it is as resilient as possible in the face of sea level rise. The primary objective of *Ho‘omau ‘O Waikīkī Kahakai* is to support stable and resilient beaches in Waikīkī by addressing ongoing beach erosion and aging shoreline structures. The project analysis and recommendations will carefully consider the unique natural, historical, cultural, and economic value of Waikīkī. The primary outcome of the project is the development of a Feasibility Study, Environmental Impact Statement (EIS), and project conceptual designs for beach improvements at Waikīkī for the Department’s Office of Conservation and Coastal Lands.

In the meantime, and to address a potential emergency situation, the Department is proposing to improve the Royal Hawaiian Groin by repairing or replacing the deteriorated existing structure with a more stable and engineered groin structure. The new groin would be designed to maintain the approximate beach width of the 2012 Waikīkī Beach Maintenance Project. Sea Engineering, Inc. developed four options including a new 180-foot-long rock L or T-head groin, a new 280-foot-long rock L or T-head groin, adaptive re-use of the existing groin as the core of a new 160-foot-long rock L-head groin, and a new 160-foot-long vertical concrete wall groin. Since no enlargement of the beach is proposed, the 280-foot-long rock L or T-head groin option was eliminated because it is larger than necessary. Sea Engineering, Inc. determined the option for a new 180-foot-long rock T-head groin would be the best engineered structure to stabilize and maintain this section of Waikīkī Beach. The new structure would be designed to withstand site-specific wave conditions and coastal hazards, such as hurricanes and sea level rise. The L or T-head is designed to diffract waves and support beach stability by reducing longshore sediment transport away from the groin. The sloping rock rubblemound structure is recommended because of its ability to provide good wave energy dissipation and minimal wave reflection towards offshore surf breaks. The project will not impact any surfing resources within Waikīkī.

Concerns raised by the general public included the effects of increasing the footprint of the groin on the ocean floor and the aesthetics of a larger, rock rubblemound groin. Most of the individuals that provided public testimony at the public hearing would like to see the groin restored to the existing design and size.

Support for the rock rubblemound 180-foot-long T-head groin option came from beach users, the hotel industry, community organizations, and the City Council. Most supporters believe the T-head option will maintain the beach best and provide for the possibility of sand accretion on the western side of the groin.

Concerns regarding construction impacts on visitors and concessions were expressed. Information will be made publicly available and coordination will be made with the lifeguards, hotels, and vendors to mitigate construction impacts.

Safety concerns from the City and County of Honolulu Lifeguards include the lifeguards' ability to manage the groin area and public access along the top of the groin. The Department has been coordinating with the lifeguards to address safety concerns and mitigate public safety issues. Possible options that have been discussed include constructing a new lifeguard tower closer to the groin to provide more lifeguard presence in the area and maintain proper signage to prevent people from walking or climbing on top of the groin.

A major concern of the local community is the impact the proposed project will have on surf spots. The existing groin is 370 feet long, including the curve to the east, and extends 250 feet from the shore. All the options being proposed extend less seaward than the existing groin. Rock rubblemound groins have very little wave reflectivity and will not be reflecting waves back towards the surf breaks. The concrete wall option would have higher wave reflectivity and a higher possibility of affecting surf breaks. The new groin would be located well landward of the nearby surf breaks, with the head about 800 feet landward of the Populars surf break riding zone.

The Department will investigate removing the submerged and broken remains of the existing groin at the end of construction. This permit is subject to a term and condition for removal of the remaining derelict materials.

Staff is in favor of a rock rubblemound structure, but prefers the option to re-use the existing groin as the core of a new 160-foot-long T-head groin. Staff believes that this alternative is the least intrusive, preserves remnants of the historic structure, and will function as a proper coastal engineering structure. The adaptive re-use option presented in the Final EA includes an L-head, however staff believes a T-head groin would allow for the potential of beach formation on the western side of the groin at Gray's Beach. Even though the adaptive re-use of the existing groin with a T-head was not specifically identified in the Final EA, the impacts of a T-head groin were effectively discussed by the first option, a 180-foot-long T-head groin. Staff has discussed the adaptive re-use alternative with Sea Engineering, Inc. and they believe that it would function similar to the rock rubblemound 180-foot-long T-head groin option.

Waikīkī Beach, and in fact the entire south shore shoreline, is an engineering marvel. It is largely manufactured from concrete, boulders, and imported carbonate sand. Surfing sites have been created and destroyed in this process, coral has been negatively impacted, and the entire ecosystem (land and sea) has changed. However, amidst all these changes, Waikīkī is still a magical place.

RECOMMENDATION

Based on the preceding analysis, staff recommends that the Board of Land and Natural Resources APPROVE this application for the option of re-using the existing groin as the core of a new 160-foot-long rock T-head groin extending into the ocean seaward of Waikīkī Beach, O'ahu, seaward of Tax Map Keys: (1) 2-6-002:005 and 006 upon submerged land subject to the following conditions:

1. The permittee shall comply with all applicable statutes, ordinances, rules, and regulations of the federal, state, and county governments, and applicable parts of this chapter;
2. The permittee shall comply with all applicable Department of Health administrative rules;
3. This authorization allows the Department to remediate the remaining derelict material of the existing groin after construction has been completed;
4. Before proceeding with any work authorized by the department or the board, the permittee shall submit four copies of the construction plans and specifications to the Chairperson or an authorized representative for approval for consistency with the conditions of the permit and the declarations set forth in the permit application. Three of the copies will be returned to the permittee. Plan approval by the Chairperson does not constitute approval required from other agencies;
5. The proposed work shall not be initiated prior to the completion of the State Historic Preservation Division's review to ensure compliance and satisfaction of HRS, 6E;

6. Unless otherwise authorized, any work or construction to be done on the land shall be initiated within two years of the approval of such use, in accordance with construction plans that have been signed by the Chairperson or an authorized representative, and shall be completed within three years of the approval of such use. The permittee shall notify the Department in writing when construction activity is initiated and when it is completed;
7. All representations relative to mitigation set forth in the accepted environmental assessment or impact statement for the proposed use are incorporated as conditions of the permit;
8. The permittee understands and agrees that the permit does not convey any vested right(s) or exclusive privilege;
9. Where any interference, nuisance, or harm may be caused, or hazard established by the use, the permittee shall be required to take measures to minimize or eliminate the interference, nuisance, harm, or hazard;
10. At the conclusion of work, the area shall be cleaned of all construction material and the site shall be restored to a condition acceptable to the Chairperson, including smoothing the beach to remove any tracks or indentions from the work;
11. Obstruction of public roads, trails, lateral shoreline access, and pathways shall be avoided or minimized. If obstruction is unavoidable, the permittee shall provide alternative roads, trails, lateral beach access, or pathways acceptable to the Department;
12. During construction, appropriate mitigation measures shall be implemented to minimize impacts to off-site roadways, utilities, and public facilities;
13. The permittee acknowledges that the approved work shall not hamper, impede, or otherwise limit the exercise of traditional, customary, or religious practices of native Hawaiians in the immediate area, to the extent the practices are provided for by the Constitution of the State of Hawai'i, and by Hawai'i statutory and case law;
14. Should historic remains such as artifacts, burials or concentration of charcoal be encountered during construction activities, work shall cease immediately in the vicinity of the find, and the find shall be protected from further damage. The State Historic Preservation Division shall be contacted (692-8015), which will assess the significance of the find and recommend an appropriate mitigation measure, if necessary;
15. Monitoring of the nearshore water quality shall be conducted in accordance with best management practices;
16. Work shall be conducted during calm weather periods to the most practical extent possible and no work shall occur if there is high surf or ocean conditions that will create unsafe work or beach conditions;
17. A summary project completion report to the Department shall be submitted within 90 days of completion of the project describing the status of the groin, as-built plans if any changes

- were made to the proposed design, what maintenance actions took place and include photographic or other quantitative evidence (beach profiles or volume calculations) of the beach conditions;
18. The permittee shall implement the proposed BMPs and monitoring and assessment plan to maintain BMPs to minimize dirt and silt from entering the ocean and the ability to contain and clean up fuel, fluid, or oil spills immediately under this authorization and immediately report any spills or other contamination(s) that occurs at the project site to the Department of Health and other appropriate agencies;
 19. The permittee shall ensure that excessive siltation and turbidity is contained or otherwise minimized to the satisfaction of all appropriate agencies, through silt containment devices or barriers, or other requirements as necessary;
 20. Appropriate safety and notification procedures shall be implemented. This shall include high visibility safety fencing, tape or barriers to keep people away from the active construction site and a notification to the public informing them of the project;
 21. All placed material shall be free of contaminants of any kind including: excessive silt, sludge, anoxic or decaying organic matter, turbidity, temperature or abnormal water chemistry, clay, dirt, organic material, oil, floating debris, grease or foam or any other pollutant that would produce an undesirable condition to the beach or water quality;
 22. The activity shall not adversely affect a federally listed threatened or endangered species or a species proposed for such designation, or destroy or adversely modify its designated critical habitat;
 23. The activities shall not substantially disrupt the movement of those species of aquatic life indigenous to the area, including those species, which normally migrate through the area;
 24. When the Department is notified that an individual activity deviates from the scope of work approved by this authorization or activities are adversely affecting fish or wildlife resources or their harvest, the Chairperson will direct the permittee to undertake corrective measures to address the condition affecting these resources. The permittee must suspend or modify the activity to the extent necessary to mitigate or eliminate the adverse effect;
 25. No contamination of the marine or coastal environment (trash or debris) shall result from project-related activities authorized under this permit;
 26. The Office of Conservation and Coastal Lands shall be notified (587-0377) in advance of the anticipated construction dates and shall be notified immediately if any changes to the scope or schedule are anticipated;
 27. The permittee shall maintain safe lateral beach access during project construction;
 28. Other terms and conditions as may be prescribed by the Chairperson; and

29. Failure to comply with any of these conditions shall render a permit void under §13-5, as determined by the Chairperson or Board.

Respectfully submitted,

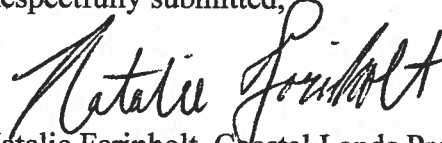

Natalie Farinholt, Coastal Lands Program Specialist
Office of Conservation and Coastal Lands

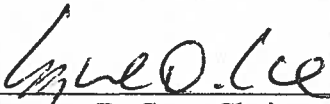

Suzanne D. Case, Chairperson
Board of Land and Natural Resources

Royal Hawaiian Groin Replacement



EXHIBIT A

Board of Land and Natural Resources Meeting

May 26, 2017

Scott Sullivan, Sea Engineering, Inc.

ssullivan@seaengineering.com

(808) 259-7966



Royal Hawaiian Groin Replacement

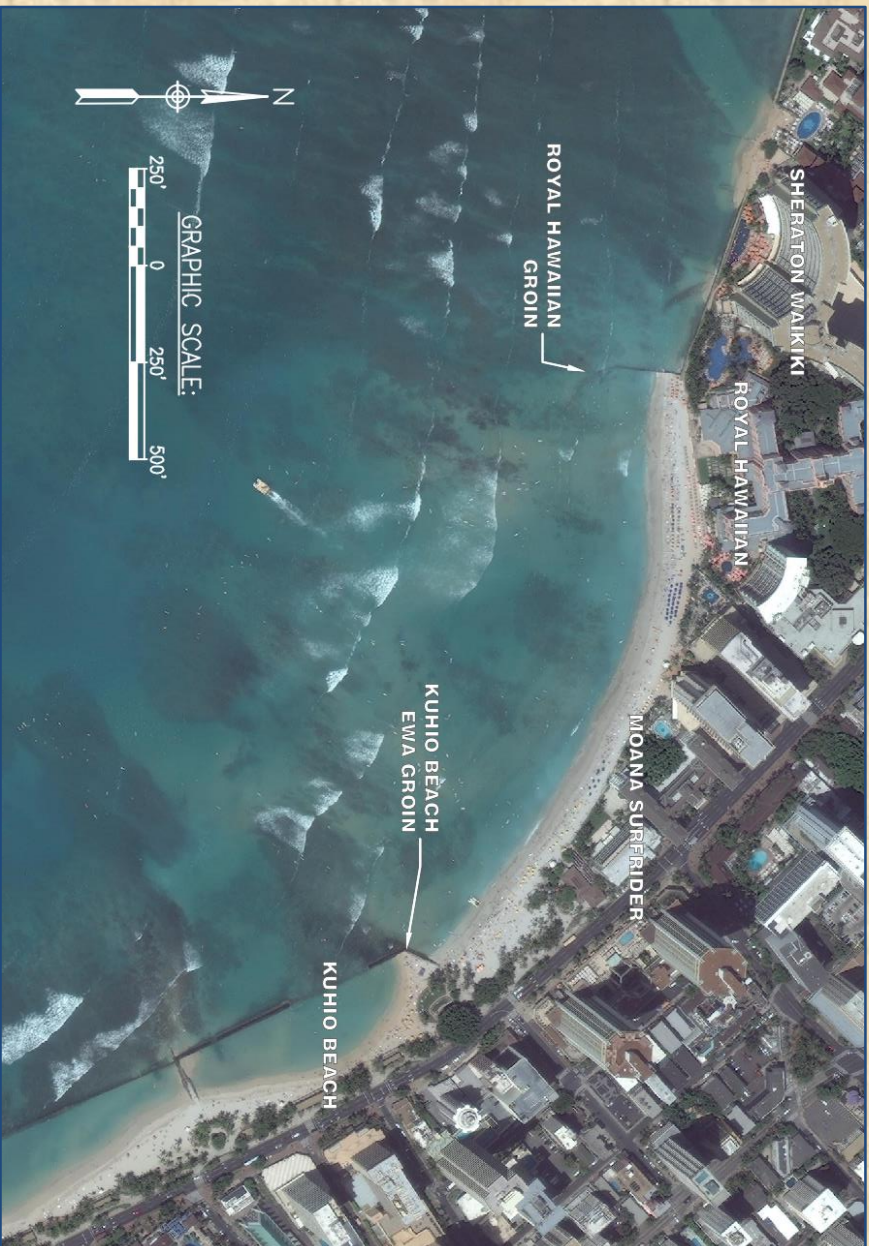

Oct 2012 aerial image



Royal Hawaiian Groin Replacement

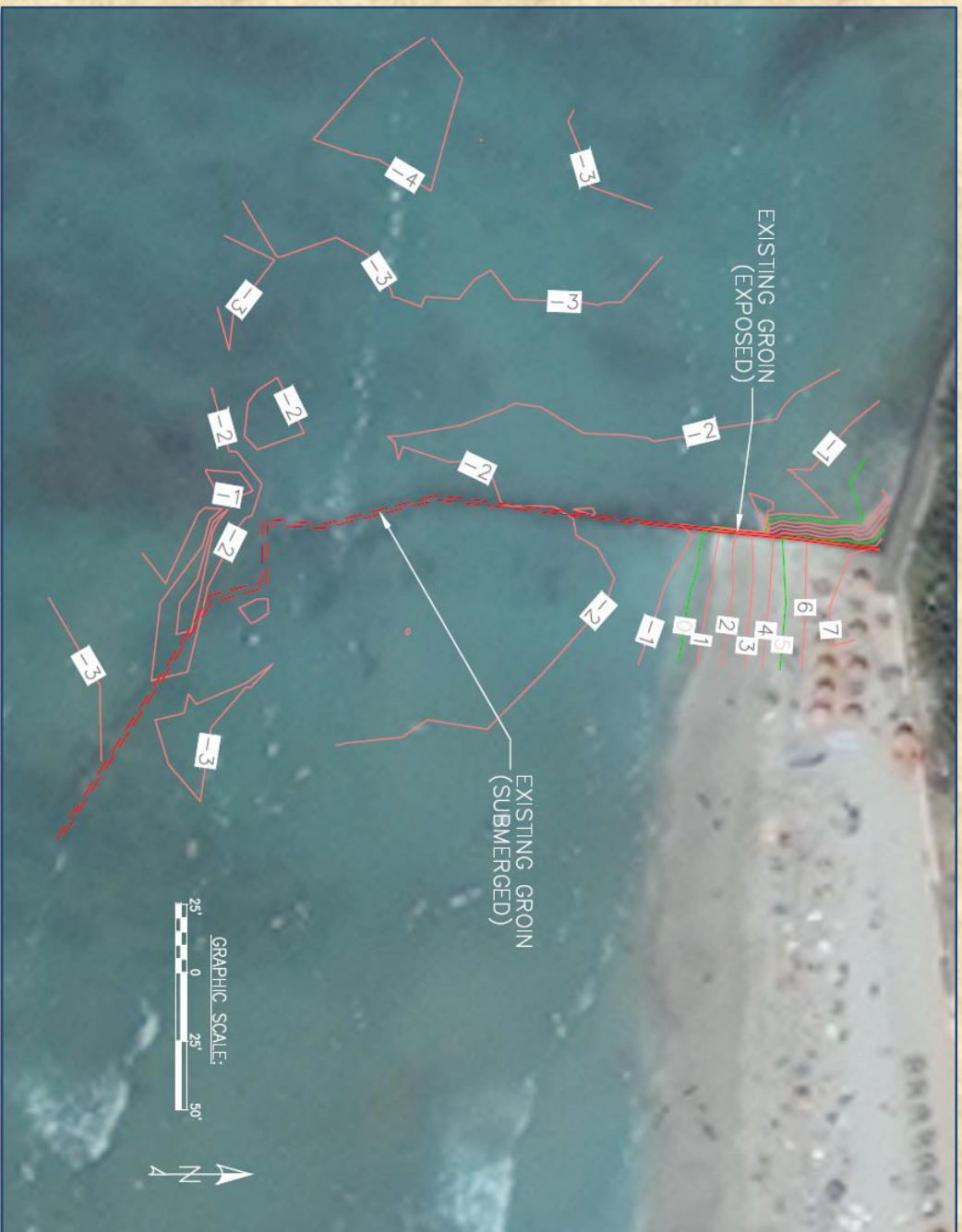

2014 Topography



Royal Hawaiian Groin Replacement

Existing Groin

- RHG Initially constructed in 1927 (170 feet)
- Lengthened in 1930 (370 feet)
- Grouted concrete blocks with stone buttress on west side—stones removed at some point
- RHG is the only groin remaining of about 10 groins constructed around that time
- Landward-most 100 feet is above water, remaining 270 feet submerged

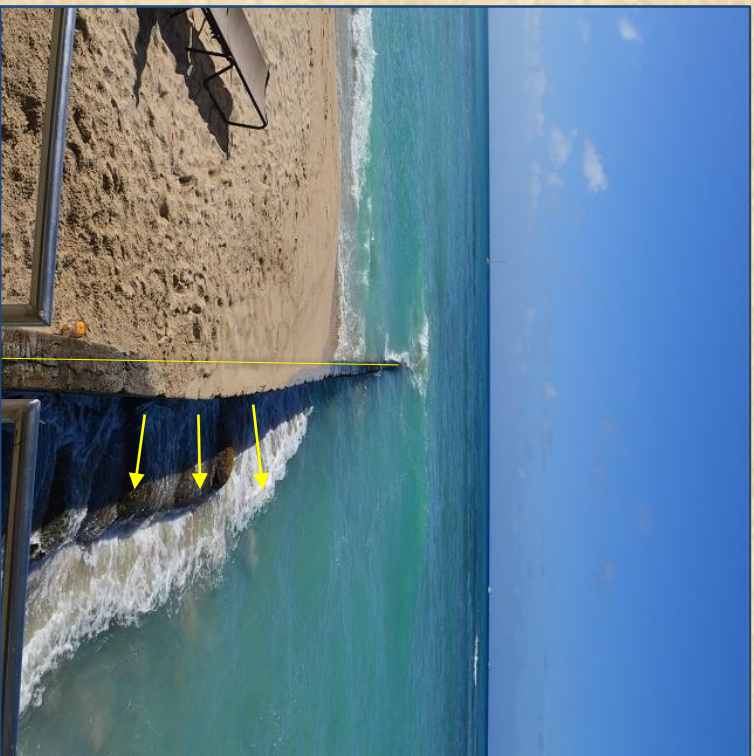

Yellow line for reference

Royal Hawaiian Groin Replacement

Existing Groin Repair

- Structural analysis determined that the existing RHG cannot withstand the design wave forces
- Strengthening existing wall to withstand design wave forces requires 5' wide by 7' tall concrete blocks on both sides of the existing wall

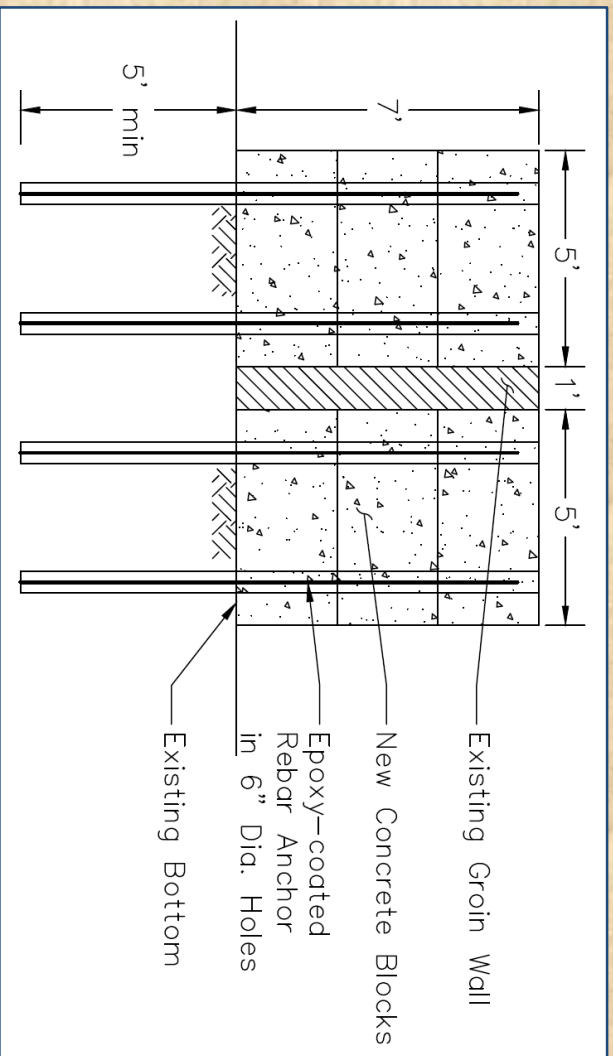

Groin strengthening



Royal Hawaiian Groin Replacement

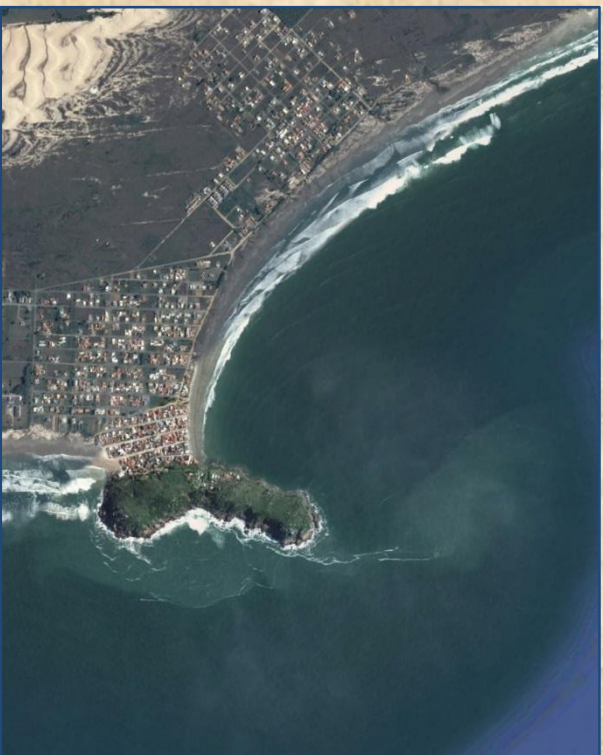

Itapiruba, Brazil

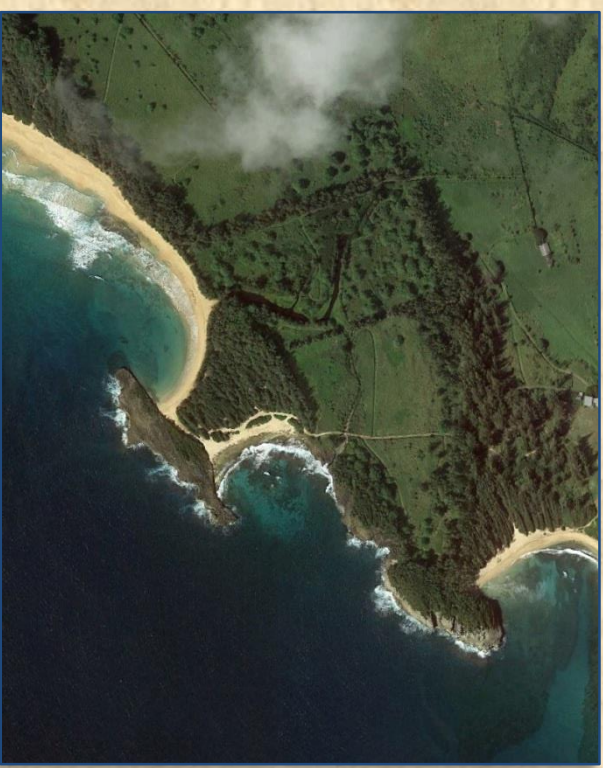

Kipu Kai Beach, Kauai

T-head Groin Design

- Concept evolved from natural headlands
- Waves diffract around semi-submerged object, headland, breakwater, T-head, etc.
- Stable beach matches the shape of the diffracted waves



Royal Hawaiian Groin Replacement

$$\frac{R}{R_0} = C_0 + C_1 \left(\frac{\beta}{\theta}\right) + C_2 \left(\frac{\beta}{\theta}\right)^2$$

$$C_0, C_1, C_2 = f(\beta)$$

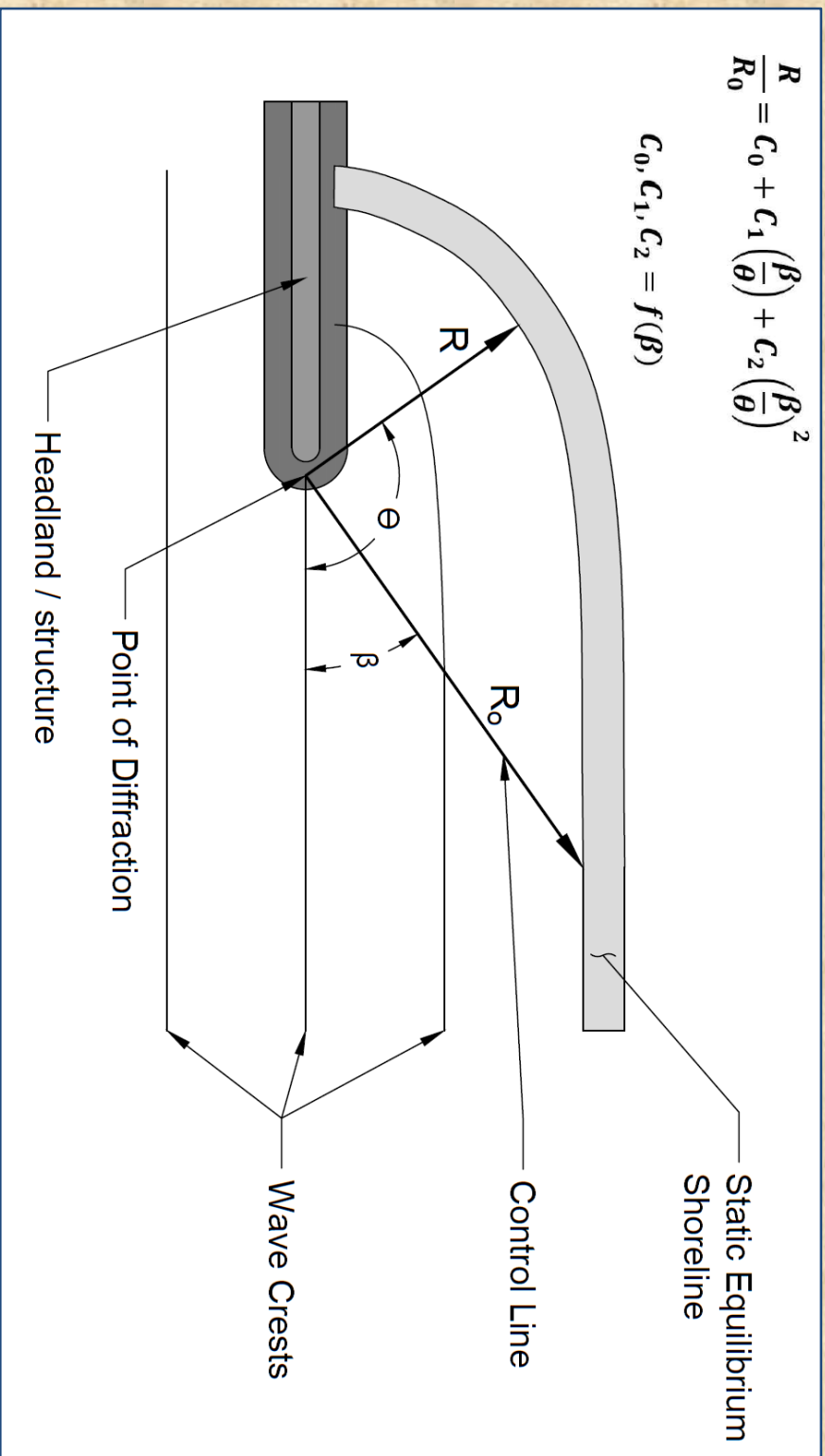

Headland bay plan shape



Royal Hawaiian Groin Replacement

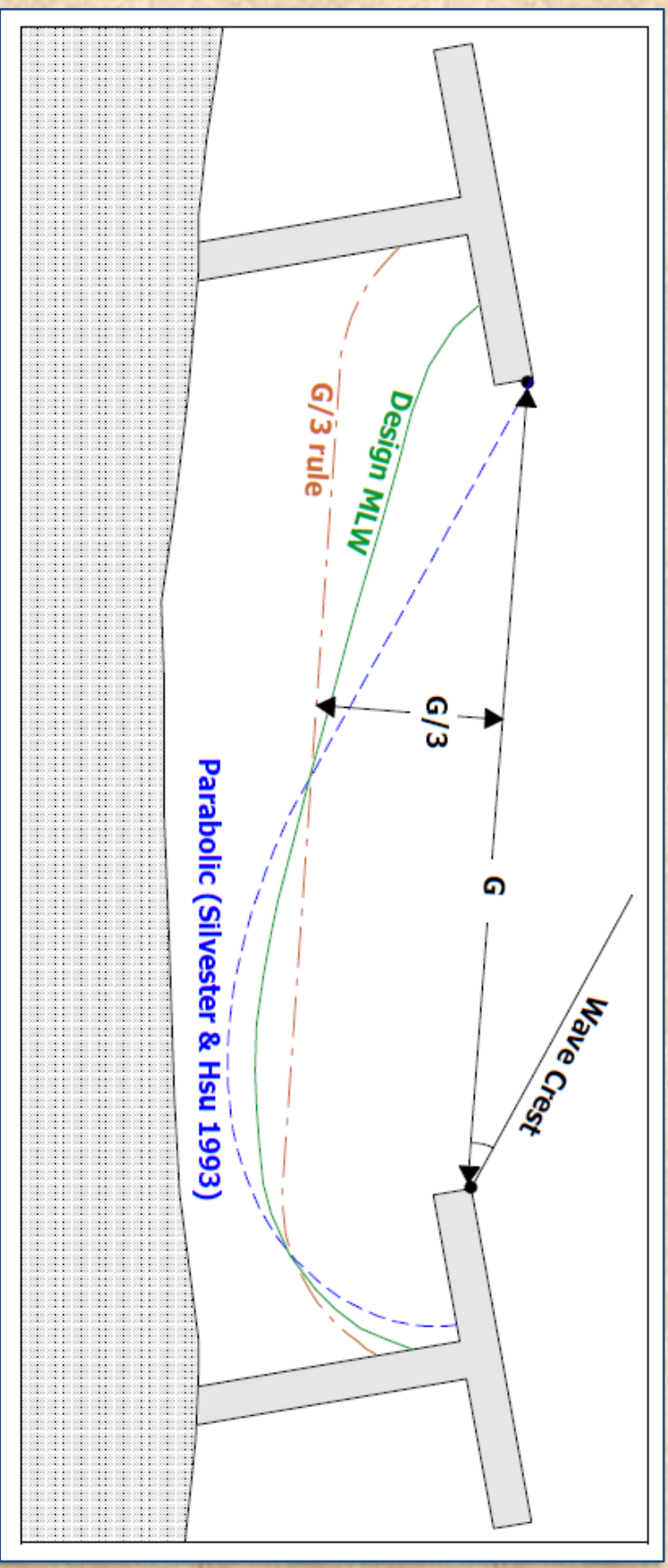

Bodge method prediction of shoreline in T-head groin compartments



Royal Hawaiian Groin Replacement



Iroquois Point, Oahu, Hawaii

Iroquois Point Beach Restoration Project

- 9 rock T-head groins on the south shore of Oahu
- Included placement of 90,000 cubic yards of sand



Royal Hawaiian Groin Replacement



Iroquois Point, Oahu, Hawaii



Royal Hawaiian Groin Replacement



Iroquois Point Beach Restoration Project

- 3 years of post-construction monitoring shows beach within cells are stable
- Awarded *2014 Best Restored Beach* by American Shore and Beach Preservation Association (ASBPA)

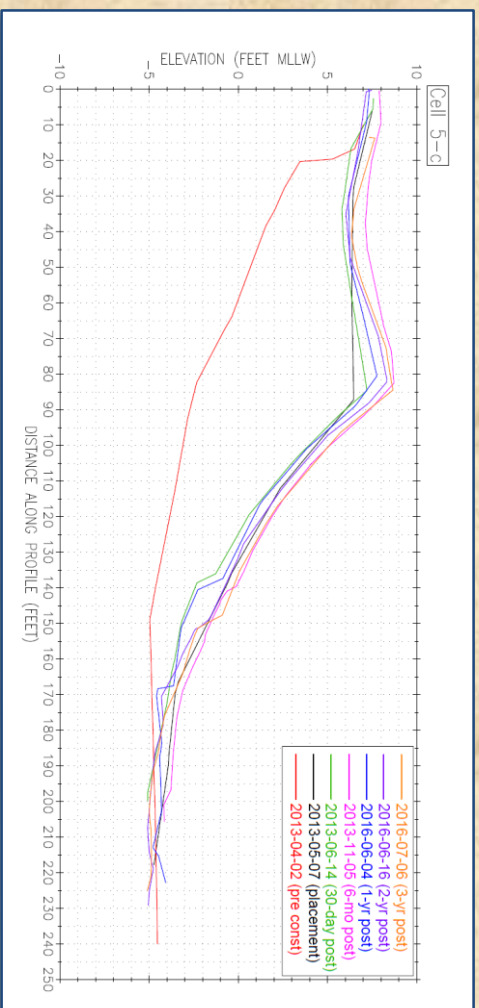

Royal Hawaiian Groin Replacement

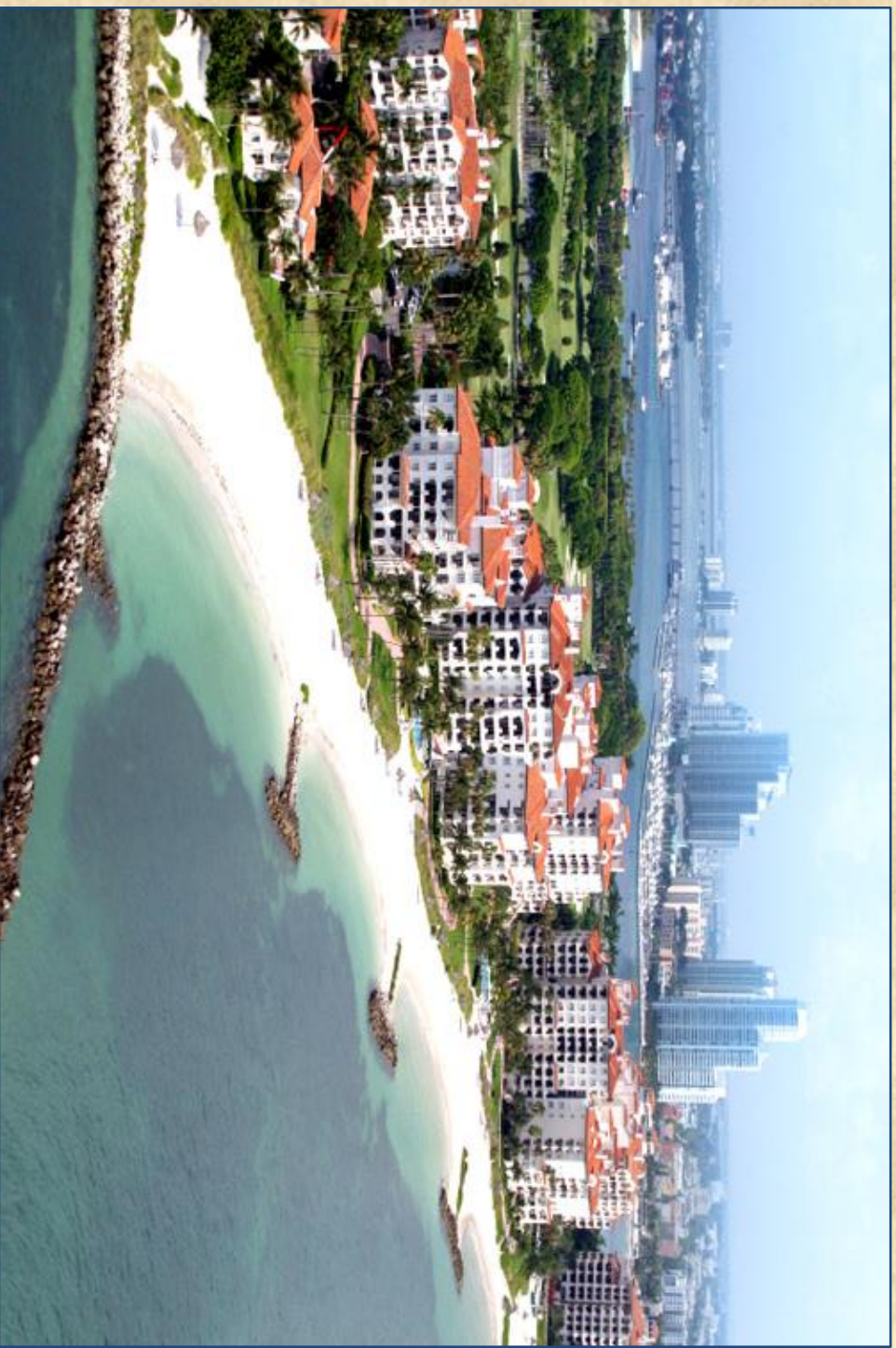

Fisher Island, Miami, Florida



Royal Hawaiian Groin Replacement



Port Everglades, Florida



Royal Hawaiian Groin Replacement

Present Condition

- Persistent westerly waves in 2011, 2015, and 2017
- Sand moves in DH direction leaving groin with little support

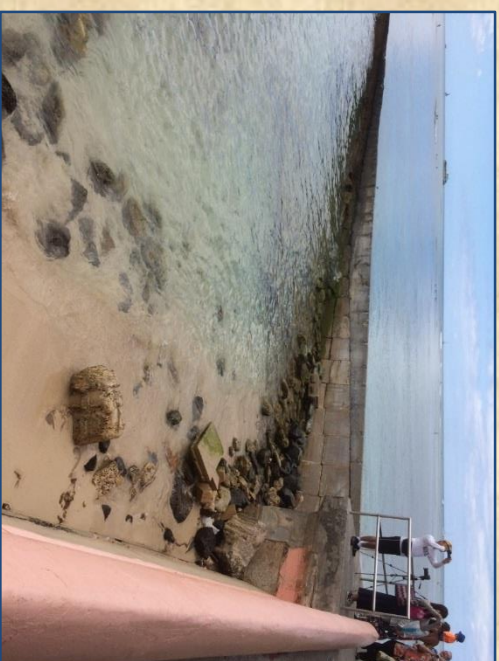
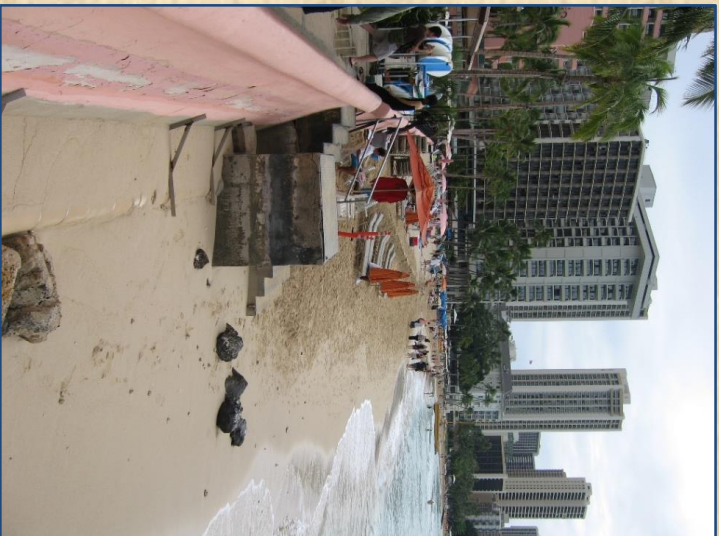

Royal Hawaiian Groin Replacement

15

Present Condition

- Groin is leaning and bowed toward the west
- Sinkholes developed following the 2012 beach maintenance project
- Geotextile lining was placed to inhibit migration of sand under and through the groin



Royal Hawaiian Groin Replacement



- GROUT between blocks is missing
- Daylight can be seen
- Blocks are undermined
- Water flows under the base
- What is holding the blocks together?

Present Condition

Royal Hawaiian Groin Replacement

Present Condition

- 45 ElcoRock bags were placed in 2012 to support groin
- Temporary solution
- Majority of bags have been displaced



2013



2017

Royal Hawaiian Groin Replacement



Submerged blocks offshore



Royal Hawaiian Groin Replacement



Collapsed blocks offshore



Royal Hawaiian Groin Replacement

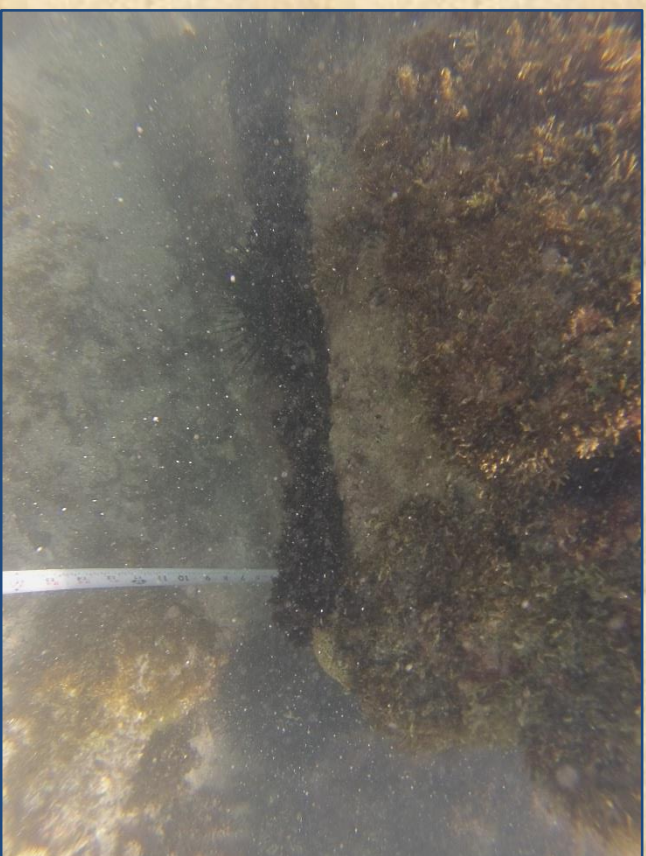
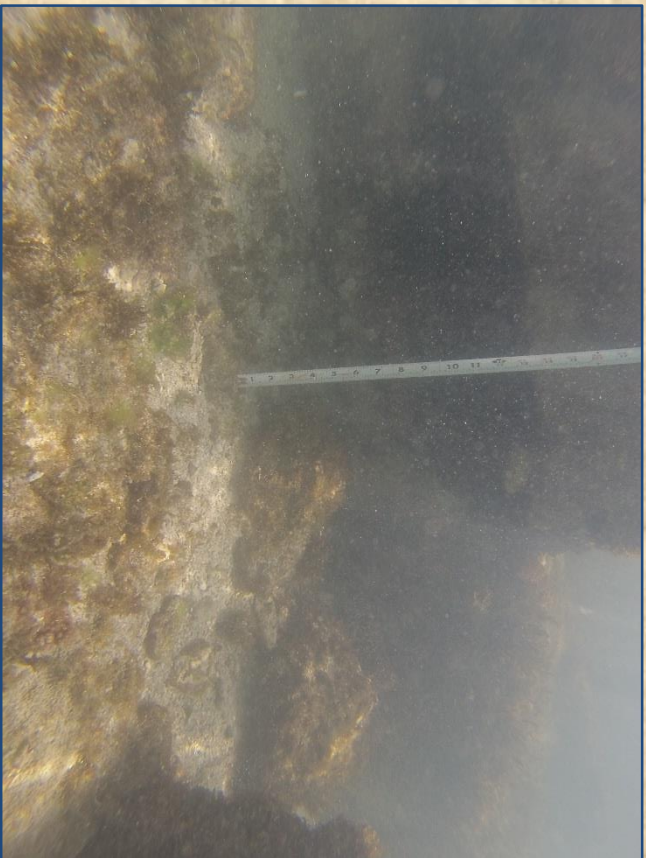

Undermining of nearshore blocks



Royal Hawaiian Groin Replacement

Potential Impacts of Groin Failure

- Would destabilize the 1,700 foot long Royal Hawaiian Beach sector in the heart of Waikiki
- Likely rapid and permanent sand loss and beach recession
- Would undo benefits of the 2012 maintenance project
- Study showed that loss of Waikiki Beach would result in up to:
 - \$2 billion loss in visitor expenditures annually
 - \$150 million in lost tax revenue annually
 - 6,350 jobs lost in the hotel industry



Royal Hawaiian Groin Replacement

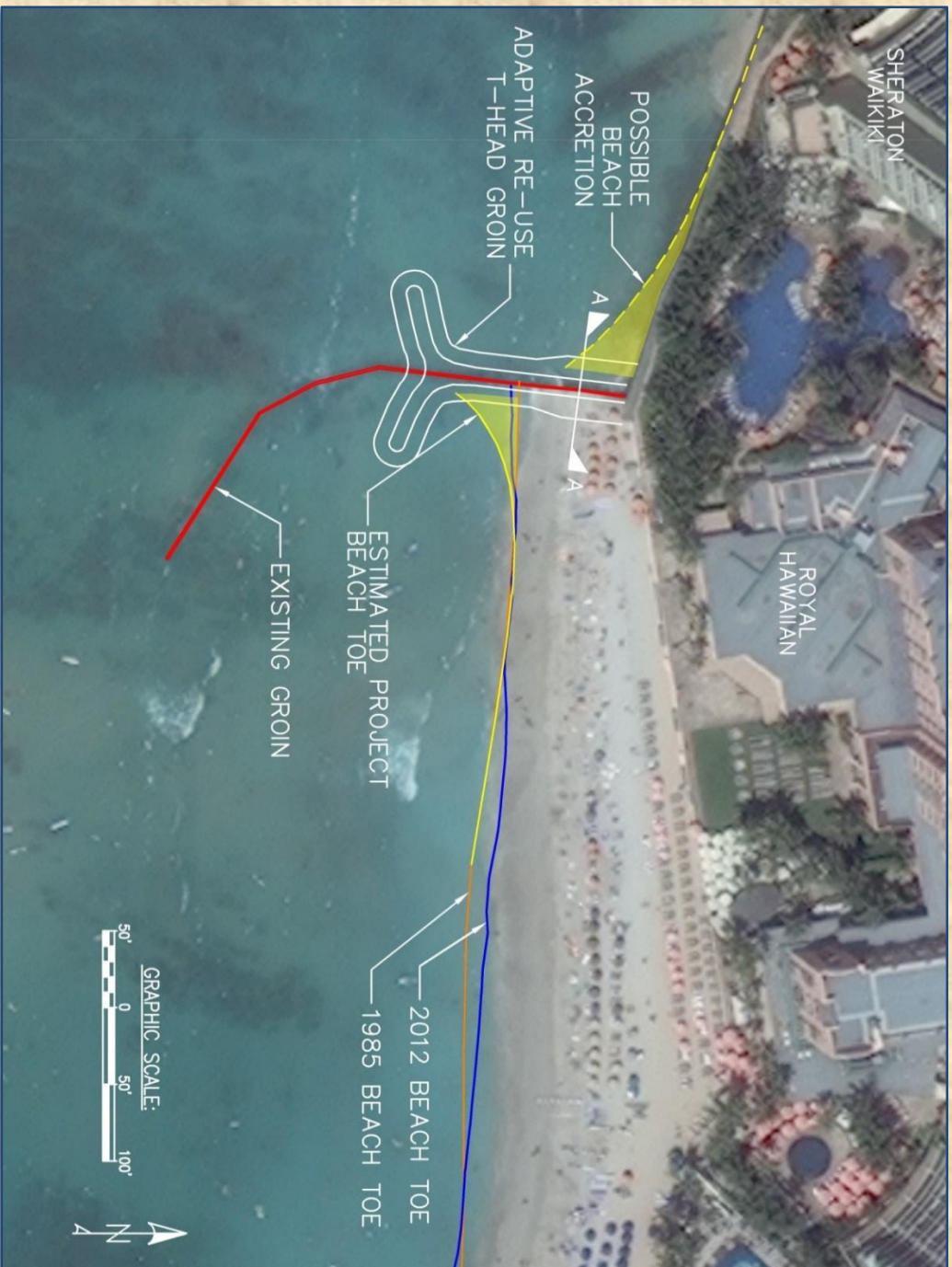

Adaptive reuse 180-foot T-head groin



Royal Hawaiian Groin Replacement

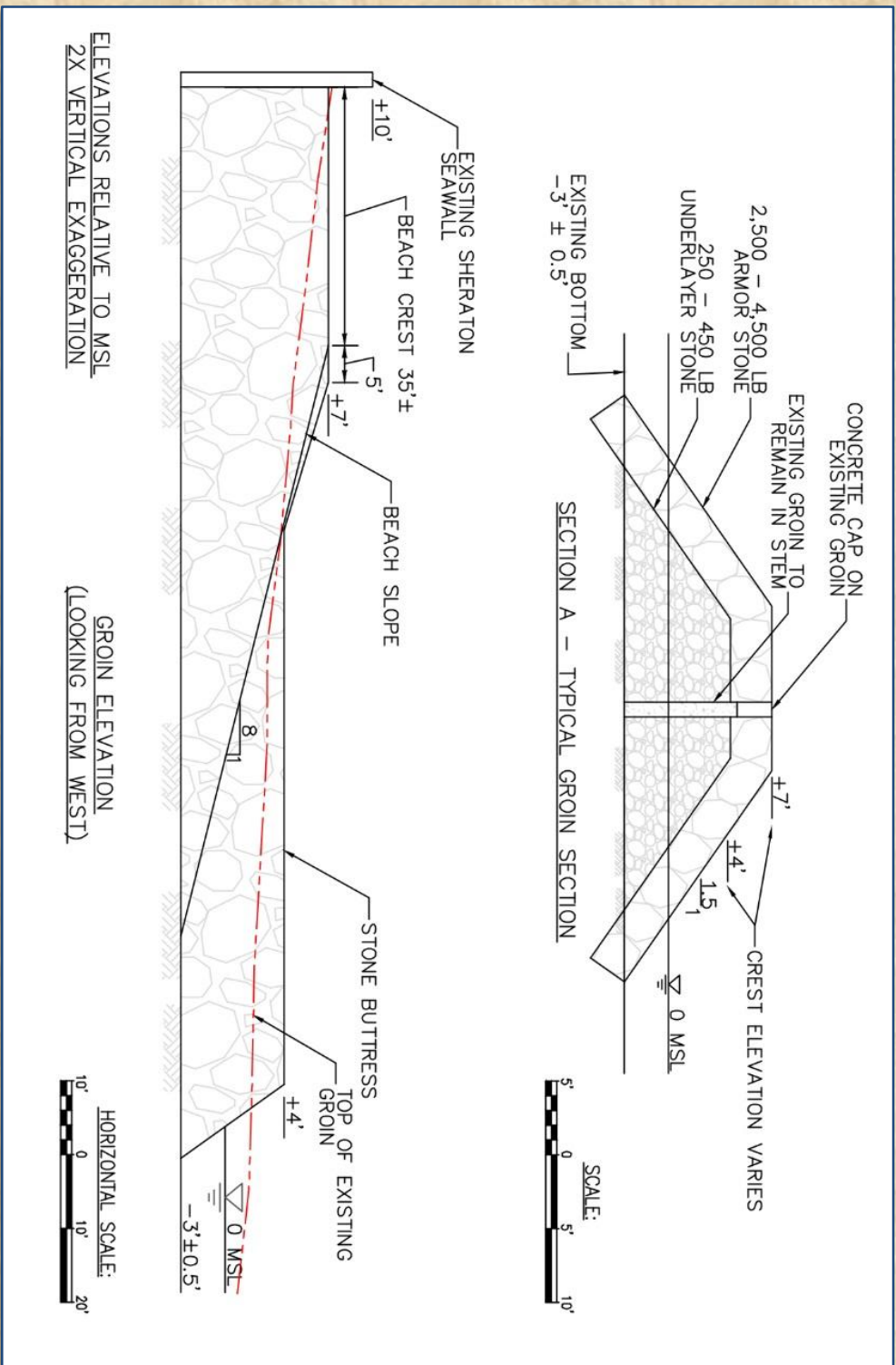

Adaptive reuse groin section and elevation views



Royal Hawaiian Groin Replacement

Wave Reflection off a Vertical Wall

- Vertical walls are generally undesirable for coastal engineering projects
- High wave reflectivity coefficient relative to beach and sloped rubble mound structures
- Reflected waves propagate offshore towards surf breaks



Incoming wave



Reflected wave



Royal Hawaiian Groin Replacement

Boussinesq Numerical Wave Modeling of Wave Reflection



Existing condition



Rock T-head groin



Vertical L-wall





Arnold T. Okubo and Associates, Inc.
CONSULTING STRUCTURAL ENGINEERS

Doc. 2017-46

May 09, 2017

Sea Engineering, Inc.
Makai Research Pier
41-305 Kalanianaʻole Highway
Waimanalo, Hawaii 96795

ATTN: Mr. Scott Sullivan, Vice President

SUBJECT: **Structural Analysis and Feasibility to Repair
an Existing Royal Hawaiian Groin Wall**

Mr. Sullivan,

A structural analysis was completed on the existing Royal Hawaiian Groin Wall located at Honolulu, Hawaii fronting Royal Hawaiian Hotel.

The following results are below:

1. The existing Royal Hawaiian Groin Wall cannot withstand the design (hurricane) wave forces condition.
2. To strengthen the existing groin wall to withstand the design (hurricane) wave forces, a new continuous concrete block segment approximately 5' wide x 7' high to varies will need to be installed. The concrete block will be installed adjacent to the existing groin wall on both sides of the existing wall.

Please call me if you have any questions.

Arnold T. Okubo, P.E.

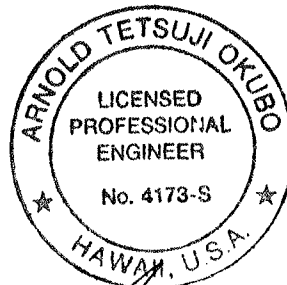
5/19/17

Exist. Royal Hawaiian G...
 w/ Sand backfill Area
 Sand finish grade 5/17

Sheet B1/B5

ARNOLD T. OKUBO & ASSOCIATES, INC.
 94-529 Ukee St., Ste. 107
 Waipahu, Hawaii 96797

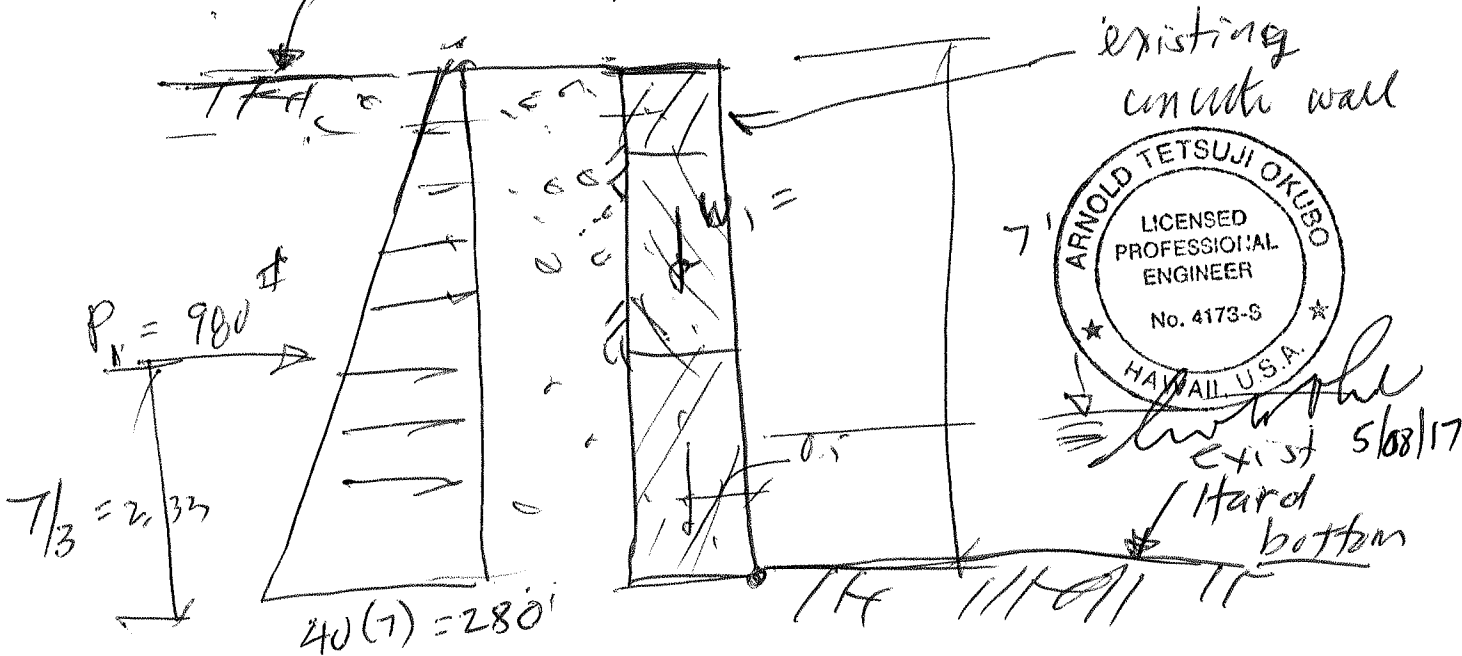

$w_a = 40 \text{ pcf active pressure}$
 $P_1 = 1/2 (280)(7) = 980 \text{ lbs}$

overturning moment
 $M_o = 980(2.33) = 2283 \text{ lb-ft}$
 $M_R = \text{righting moment}$

$w_1 = 1 \times 7 \times 150 = 1050 \text{ lbs}$
 $w_2 = 1 \times 7 \times 150 = 1050 \text{ lbs}$

\bar{x}	M_R
0.50	525 ^{lb-ft}

SF safety factor - overturning = $\frac{525}{2283} = 0.23 < 1.0 = \text{neutral stability w/ no safety factor}$

Recommended S.F. = 2.0

NO GOOD

Exist wall overturning SF < 2.0
 wall will overturn and fail -
 wall will need to be stabilized
 with added strengthening

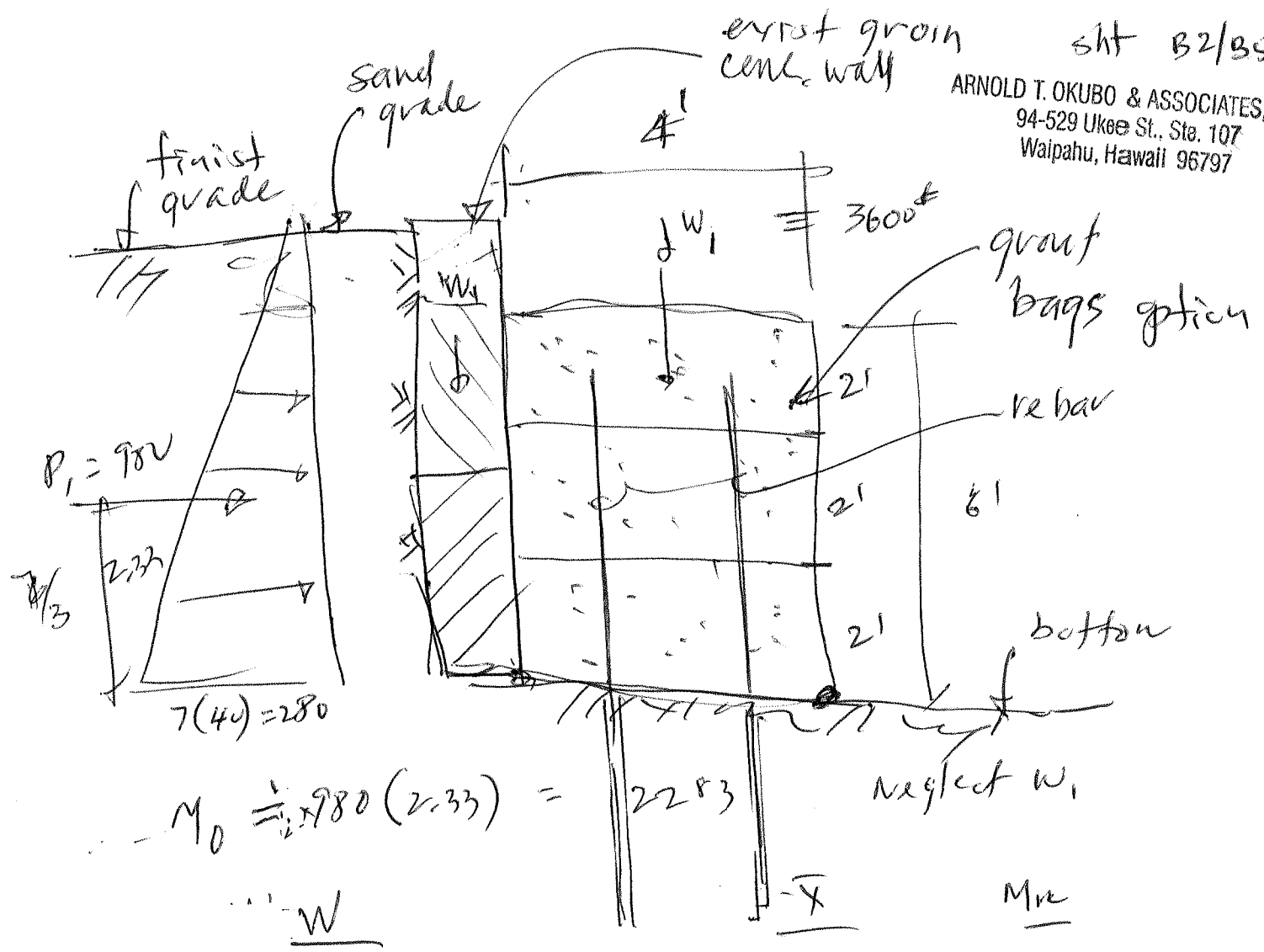

$$M_0 = \frac{1}{2} \times 980 (2.33) = 2283$$

neglect W_1

$$W_2 = 4 + 6 + 1 \times 150 = 3800 \text{ lb}$$

$$\frac{M_u}{W_2} = \frac{2283}{3800} = 0.6$$

$$SF \text{ overturning} = \frac{7200}{2283} = 3.15 > 2.0$$

OK

Alternative strengthening of Existing Groin

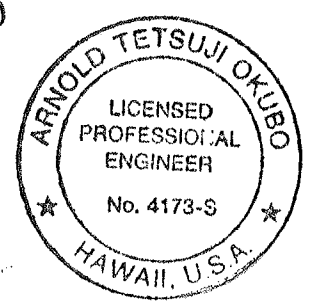

ARNOLD T. OKUBO & ASSOCIATES, INC.
94-529 Ukee St., Ste. 107
Waipahu, Hawaii 96797

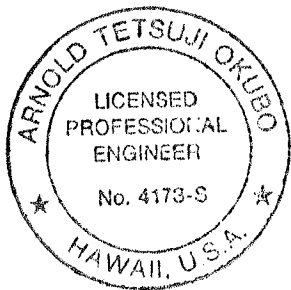
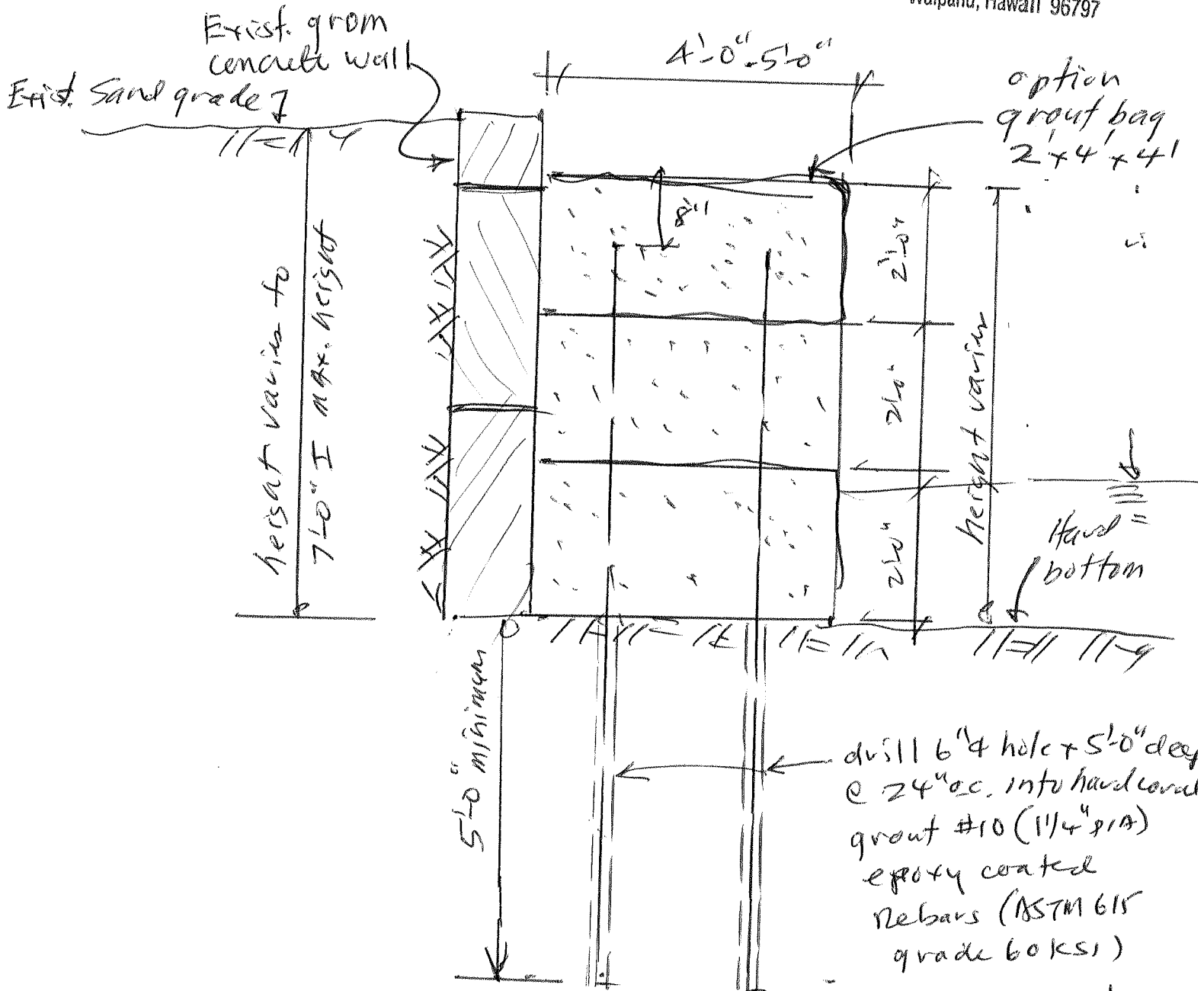

SECTION

SC: 1/2" = 1'-0"

Alternate No. 1
Proposed Strengthening of existing
Royal Hawaiian Groin.

(Alternate helical anchors, option.)

(drill & embed into hard coral)

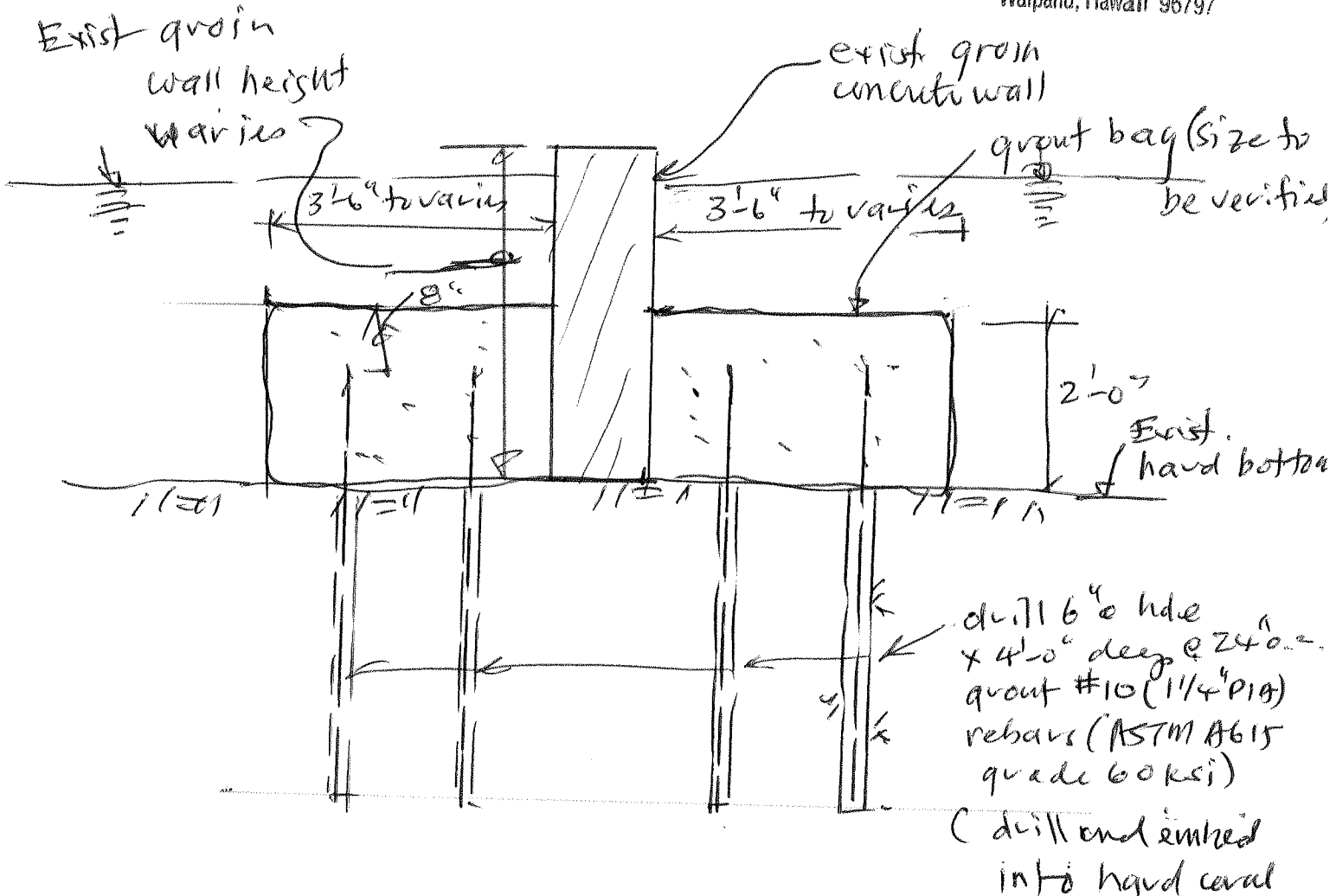

SECTION
SC: 1/2" = 1'-0"

(Alternate helical anchor option)

PROPOSED STRENGTHENING OF
EXIST. ROYAL HAWAIIAN GRAIN

SHT B5/B5

ARNOLD T. OKUBO & ASSOCIATES, INC.
94-529 Ukee St., Ste. 107
Walpahu, Hawaii 96797

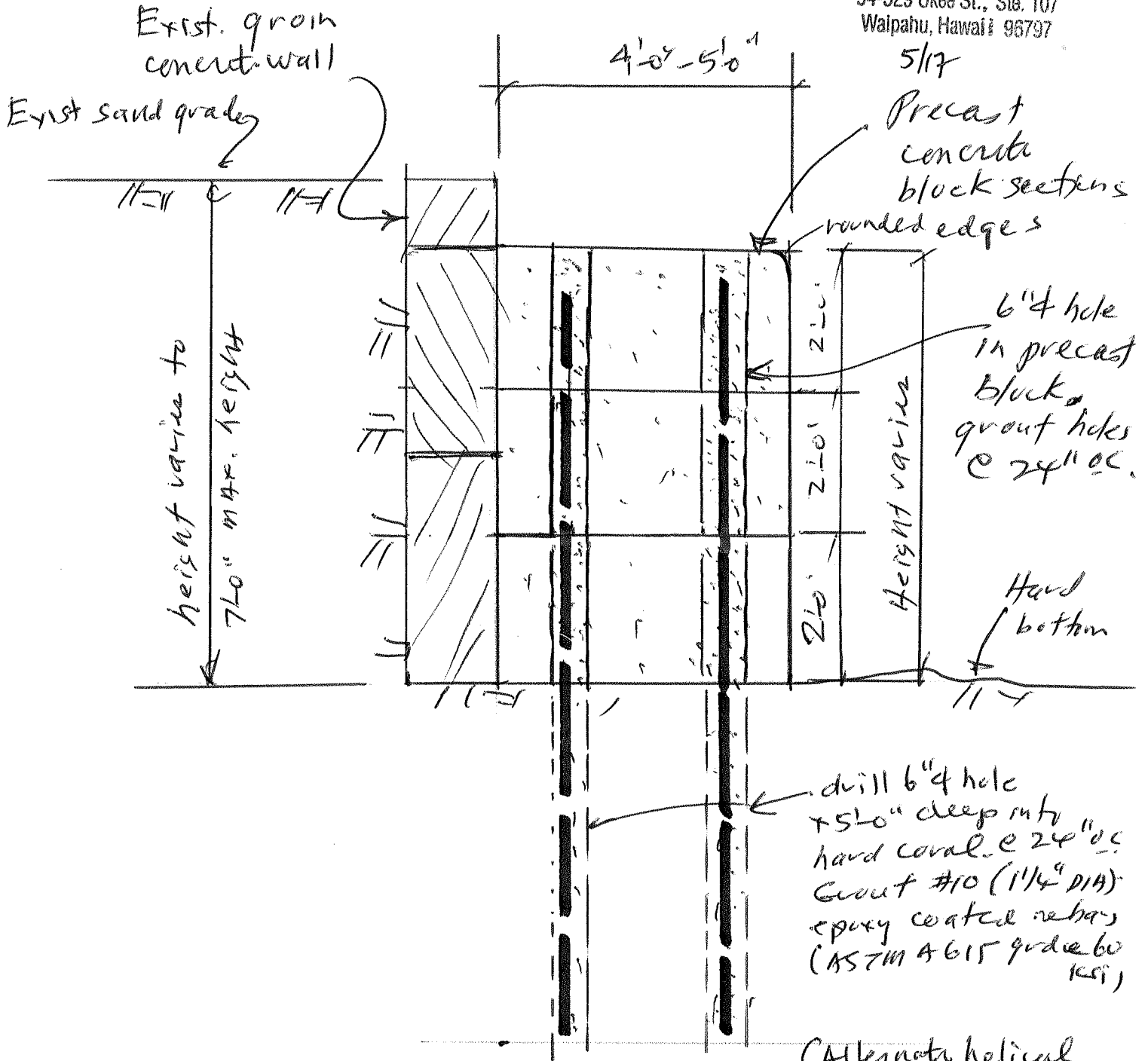

SECTION

SC: 1/2" = 1'-0"

(Alternate helical anchor option)
Need soil analysis report

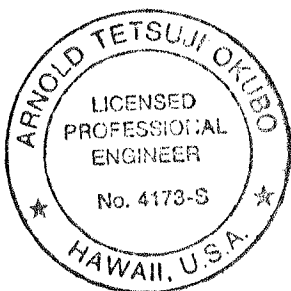

Alternate No. 2

Proposed Strengthening of existing Royal Hawaiian Grain

Exist conc. wall groin - structural analysis sht A1/A3

Design (hurricane condition) 5/17

Exist concrete wall groin

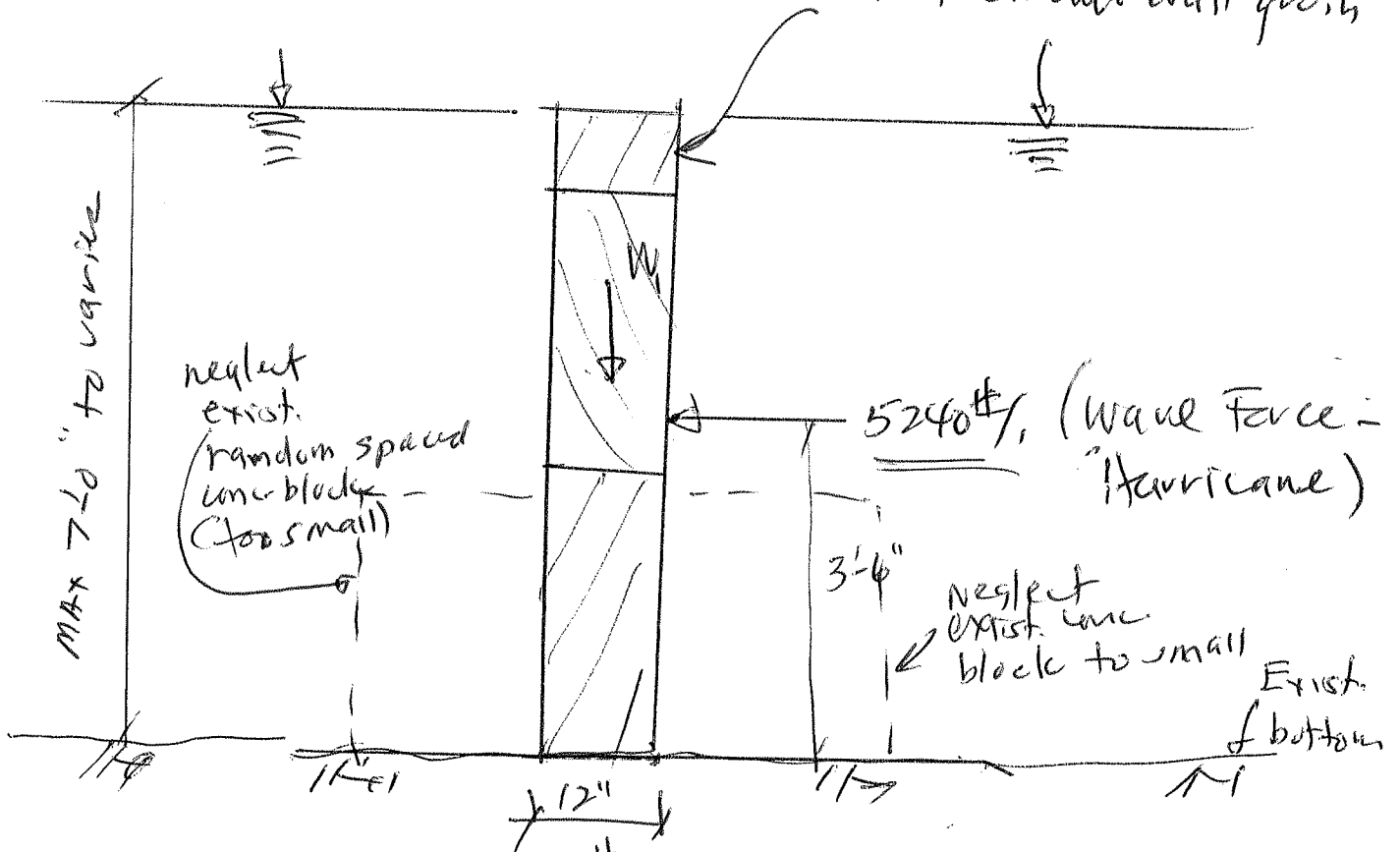

neglect exist. random spaced conc. block (too small)

5240 lb, (Wave Force - Hurricane)

neglect exist. conc. block too small

Exist. bottom

$$M_D = 5240(3.5) = 18,340 \text{ lb-ft}$$

$$W_1 = 1 \times 150 \times 7 = 1050 \text{ lb}$$

$$F = 0.50'$$

$$\frac{M_R}{A} = 525$$

$$\text{Safety Factor w/turning} = \frac{525}{18,340} = 0.0286 < 1.0 \text{ neutral stability}$$

Exist Wall no good

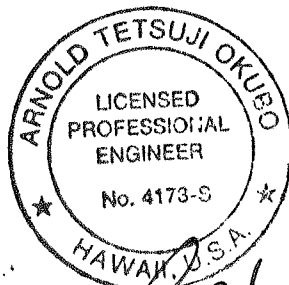

5/19/17

ARNOLD T. OKUBO & ASSOCIATES, INC.
94-529 Ukee St., Ste. 107
Waipahu, Hawaii 96797

CALCULATION FOR WAVE FORCES

shd A2/A3

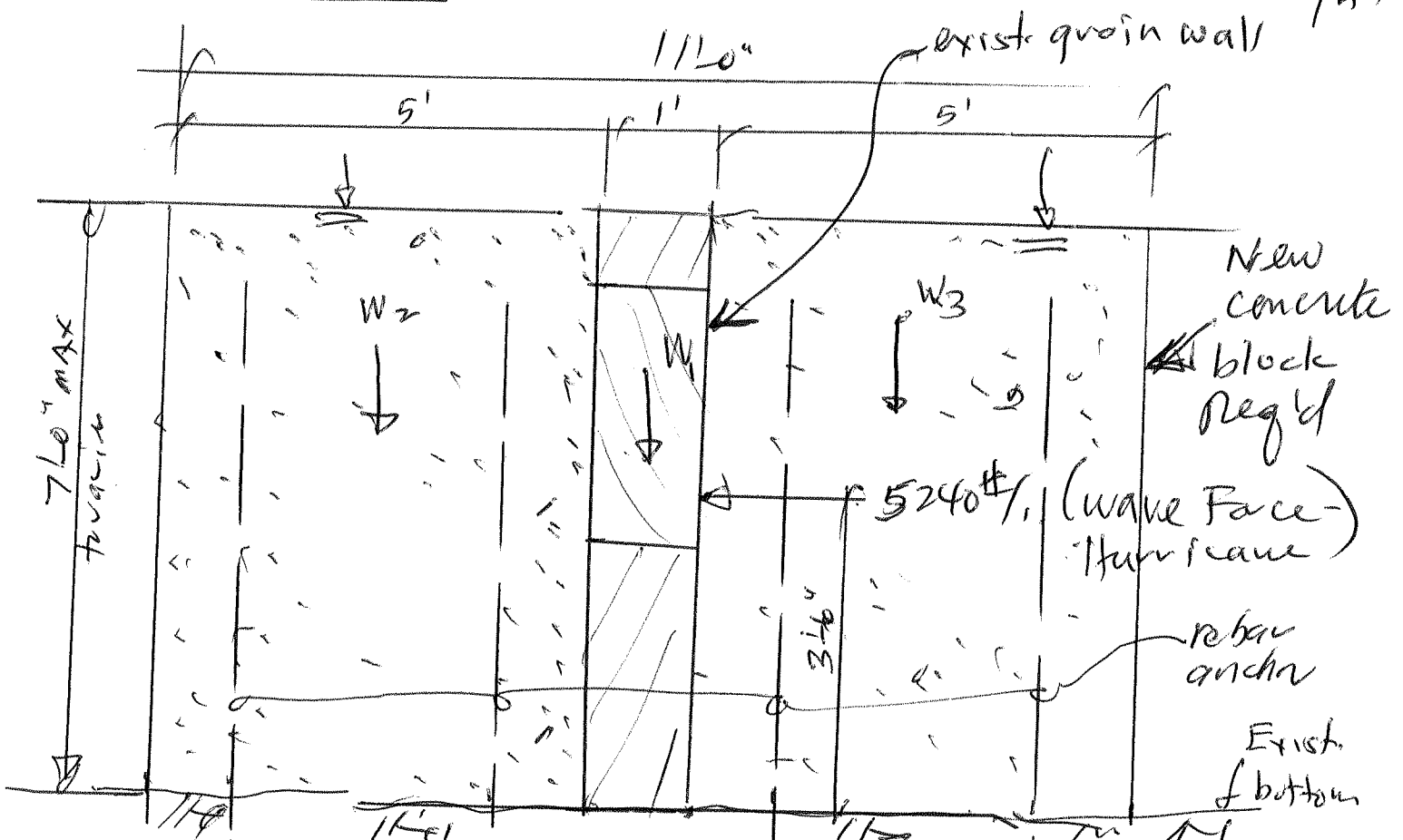

concrete in water
 $W_c = 150 - 62 = 88 \text{ pcf}$

overturning moment, $M_o = 5240(3.5) = 18,340 \text{ ft}\cdot\text{lb}$

$W_i, \text{lb.}$	$\bar{x}, \text{ft.}$	$M_{ri}, \text{ft}\cdot\text{lb.}$
$W_2 = 88 + 5' + 7' = 3080 \text{ lb}$	2.50'	7700 ft·lb
$W_1 = 88 + 7' \times 1 = 616$	4.50'	2772 ft·lb
$W_3 = 88 + 5' + 7' \times 1 = 3080$	8.5'	26,180 ft·lb
	ΣM_{ri}	$= 36,652 \text{ ft}\cdot\text{lb}$

Safety factor against overturning, $SF = \frac{36,652}{18,340} = 2.0$
 (reg'd 5' x 7' concrete block each side)

ARNOLD T. OKUBO & ASSOCIATES, INC.
 94-529 Ukee St., Ste. 107
 Waipahu, Hawaii 96797

okay

ALTERNATE STRENGTHENING
EXIST GROIN FOR WAVE FORCES

Sh. A3/A3

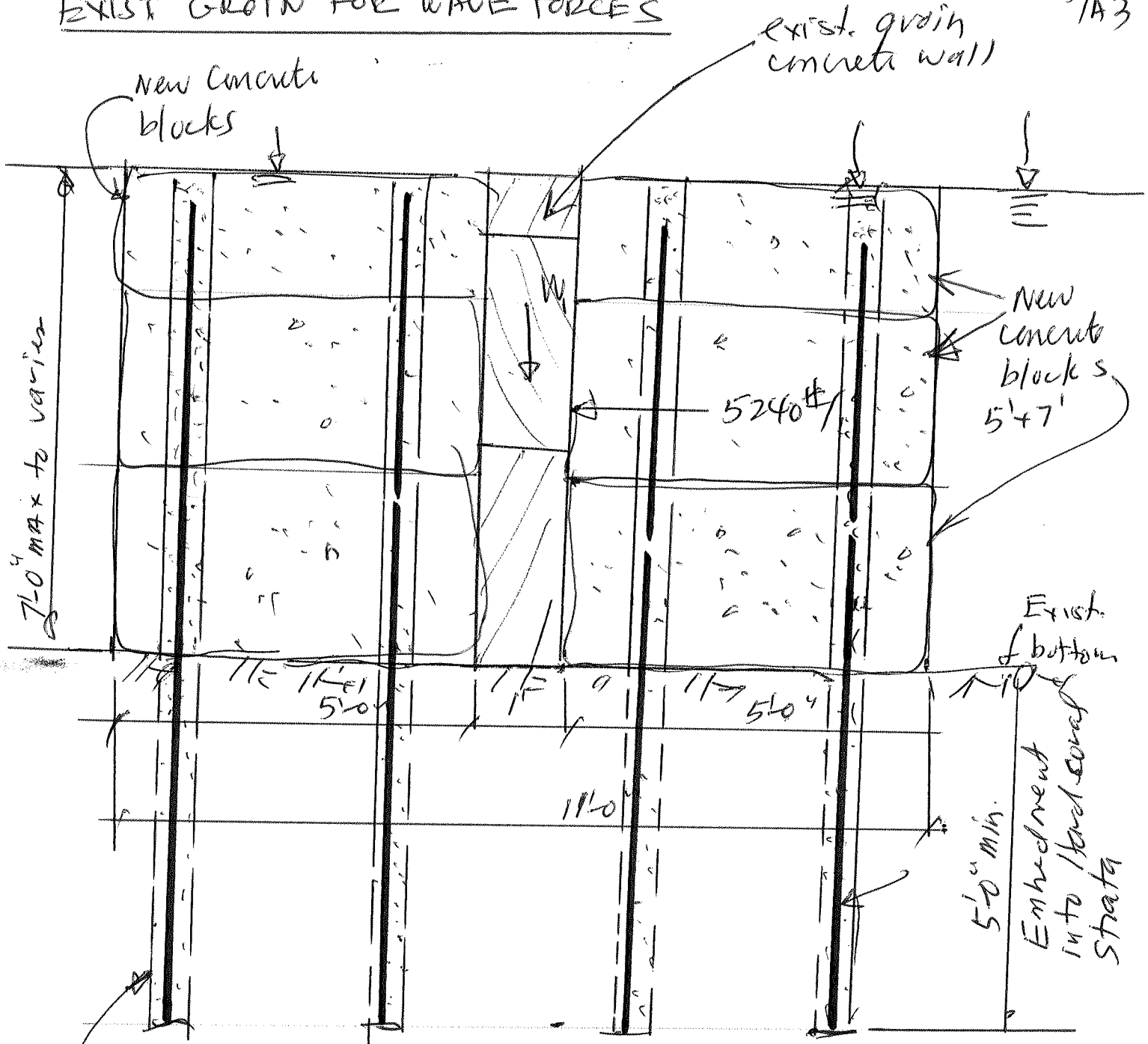

Drill 6" dia hole x 5'-0" deep @ 24" o.c. into hard coral strata.

REPAIR EXIST. GROIN WALL

*Grout #10 (1 1/4" DIA) epoxy coated rebar (ASTM 615 grade 60ksi) (Alternate helical and/or possible)

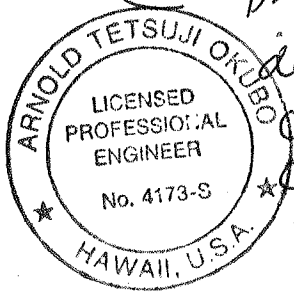

SECTION - REPAIR EXIST GROIN / STRENGTHENING
 SC: 1/2" = 11'-0"

ARNOLD T. OKUBO & ASSOCIATES, INC.
 94-529 Ukee St., Ste. 107
 Waipahu, Hawaii 96797

EXHIBIT 1

Map of Oahu

Legend

 Project Location



20 23 24
1951 11 20
20 11 20

1 - 1 - 02 1 BT 01

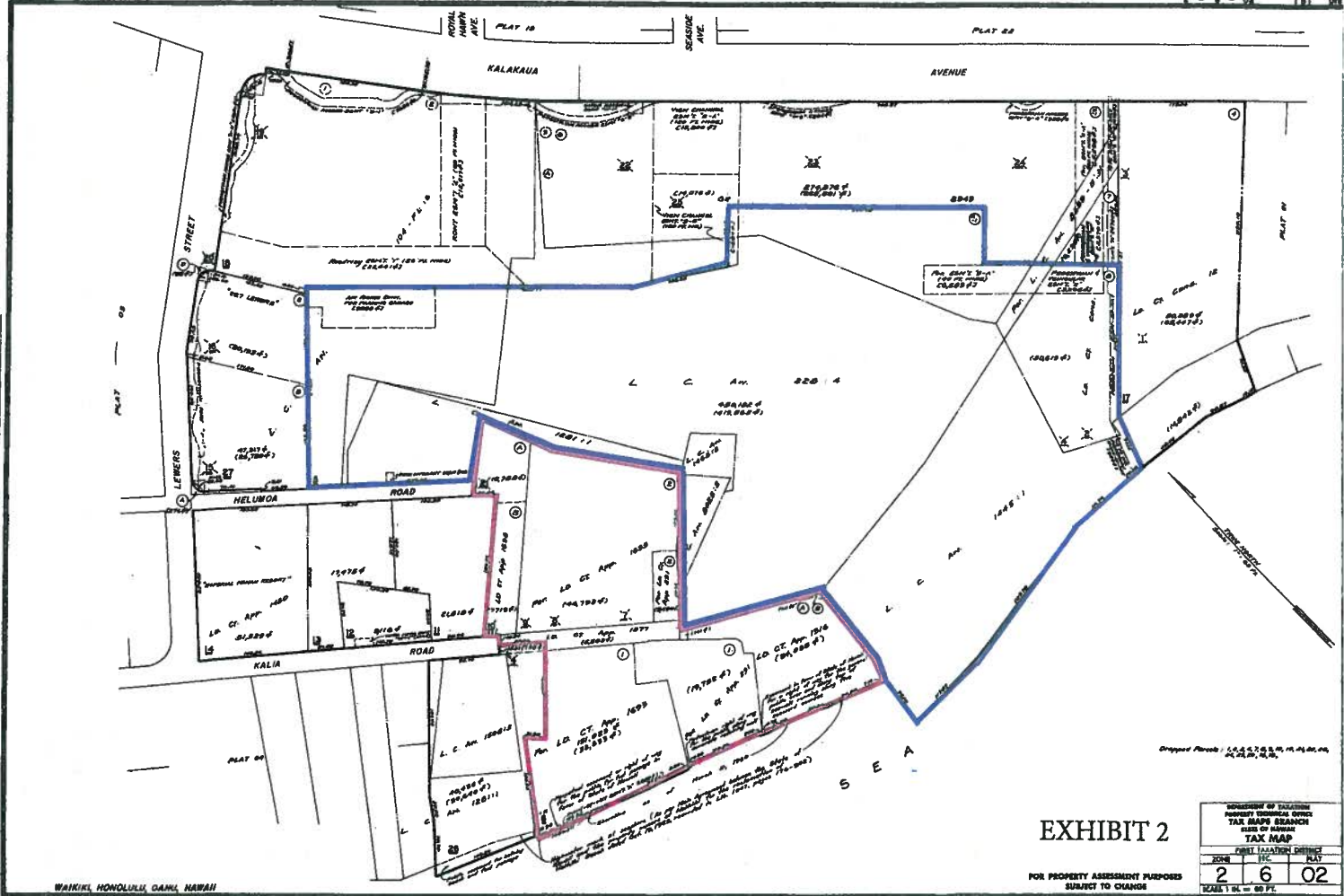

WAIKIKI, HONOLULU, OAHU, HAWAII

EXHIBIT 2

FOR PROPERTY ASSESSMENT PURPOSES
SUBJECT TO CHANGE

DEPARTMENT OF TAXATION PROPERTY TAXATION DIVISION TAX MAPS BRANCH BUREAU OF MAPS TAX MAP		
FIRST EDITION DATED		
ZONE	PLC	PLAT
2	6	02
SCALE 1" = 60 FT.		

DRAWN BY: J. W. B. 1951
 CHECKED BY: J. W. B. 1951
 APPROVED BY: J. W. B. 1951
 DATE: 11/20/51

EXHIBIT 3

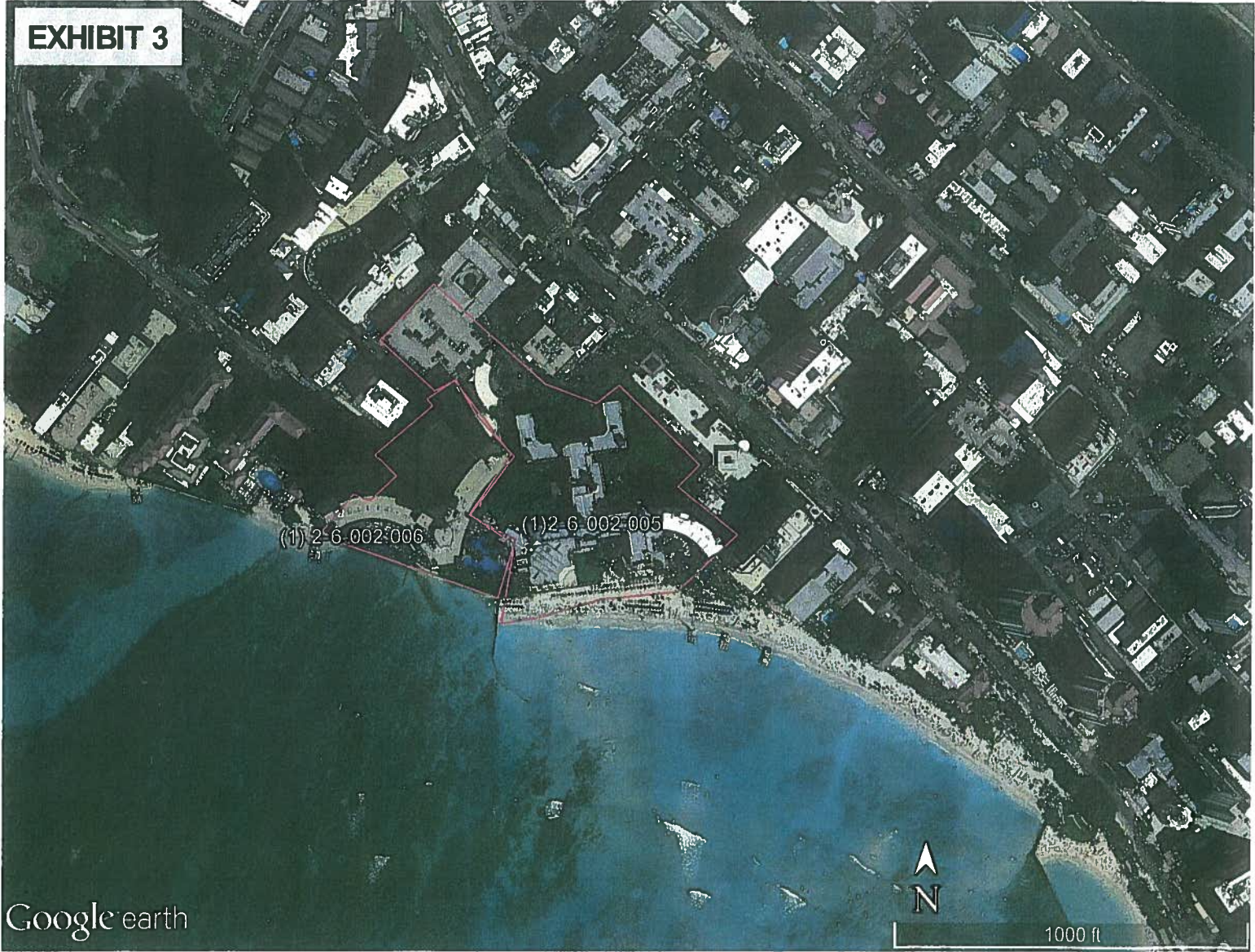

Google earth



1000 ft



EXHIBIT 4

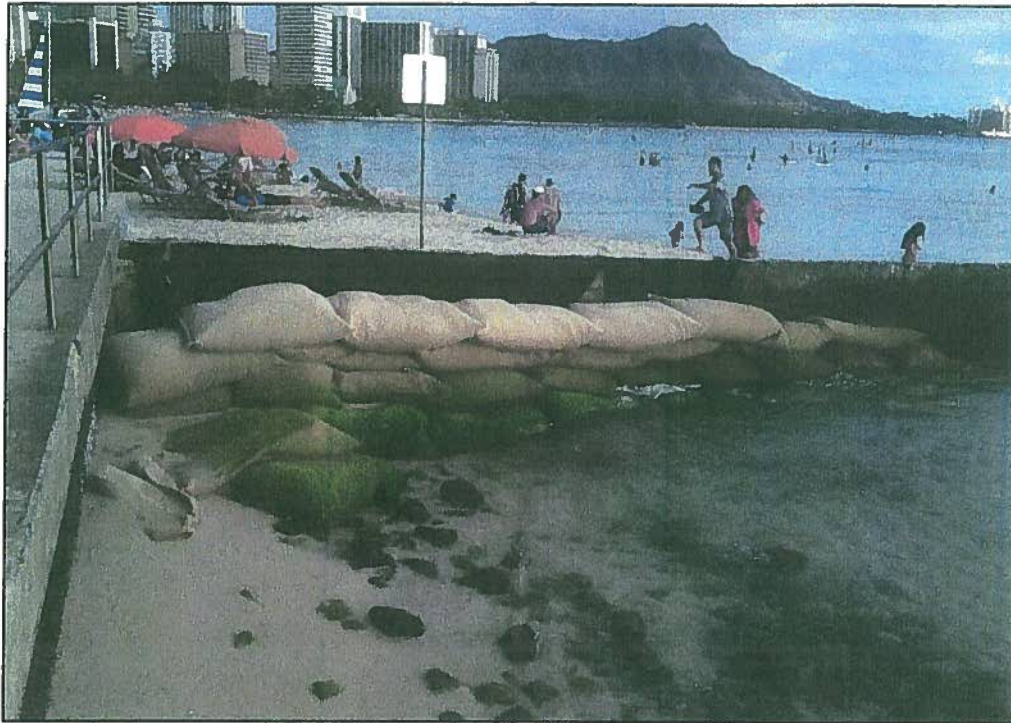

ElcoRock sand bags one month after placement (photo date January 21, 2013)

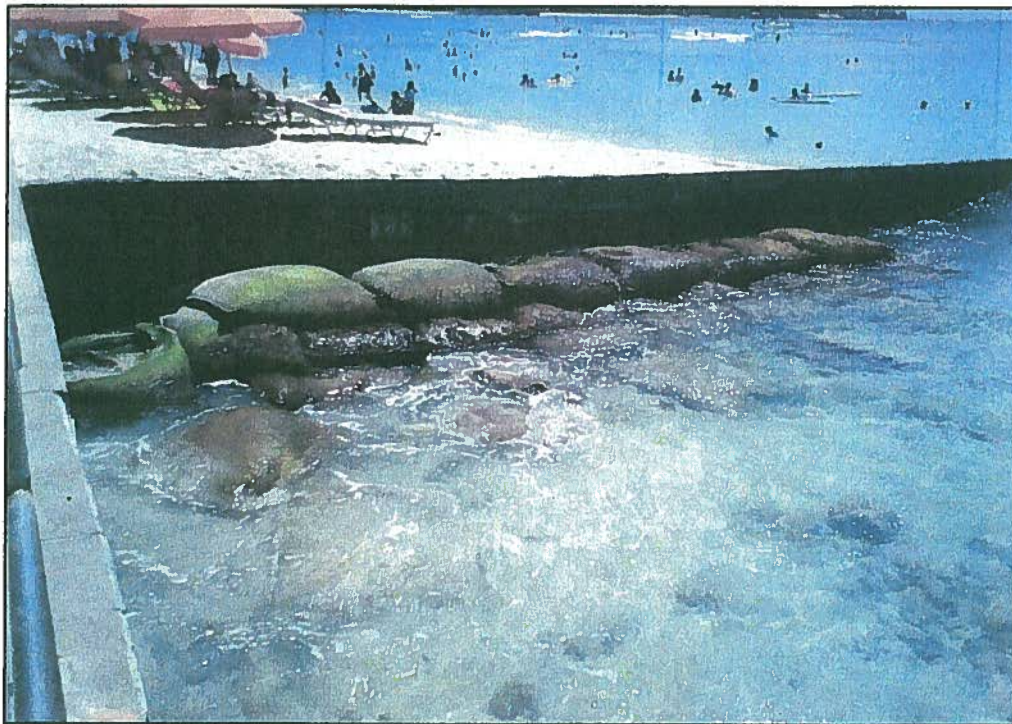

Several displaced ElcoRock sand bags (photo date September 24, 2014)

EXHIBIT 5

Summary Comparison of Groin Improvement Options

	Existing Condition	Option 1	Option 2	Option 3	Option 4
Groin type	Concrete block	Rock rubblemound w/concrete core	Rock rubblemound w/concrete core	Adaptive re-use w/ rock rubblemound	Concrete wall
Configuration	L head	L or T head	L or T head	L head	L head
Length (along crest)	370 ft	180 ft	280 ft	160 ft	160 ft
Crest elevation	+8 to -3 ft.	+7 to +4 ft	+7 to +4 ft	+7 to +4 ft	+7 to +4 ft
Footprint on seafloor					
L head	550 sf	5,850 sf	9,050 sf	5,990 sf	1,100 sf
T head	n/a	7,440 sf	12,080 sf	n/a	n/a
Volume ⁽¹⁾					
L head	n/a	910 cy	1,320 cy	1,100 cy	190 cy
T head	n/a	1,240 cy	1,780 cy	n/a	n/a
Energy reflection ⁽²⁾	60% ⁽³⁾	20%	20%	20%	60%
Construction cost					
L head	n/a	\$880,000	\$1,510,000	\$1,240,000	\$910,000
T head	n/a	\$1,200,000	\$1,730,000	n/a	n/a

⁽¹⁾ The volume is a measure of the mass of the structure

⁽²⁾ The percentage of the incoming wave energy that is reflected back seaward

⁽³⁾ Assumes the existing groin is in its original upright position

EXHIBIT 6

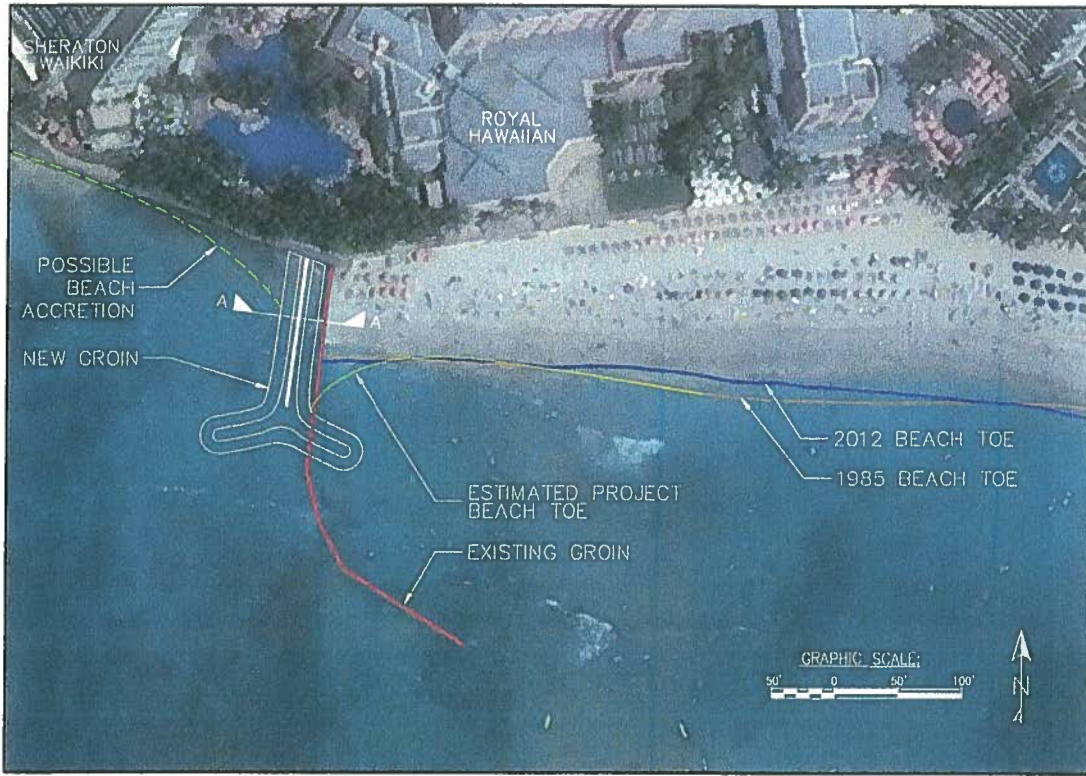

Plan view of 180-foot long groin

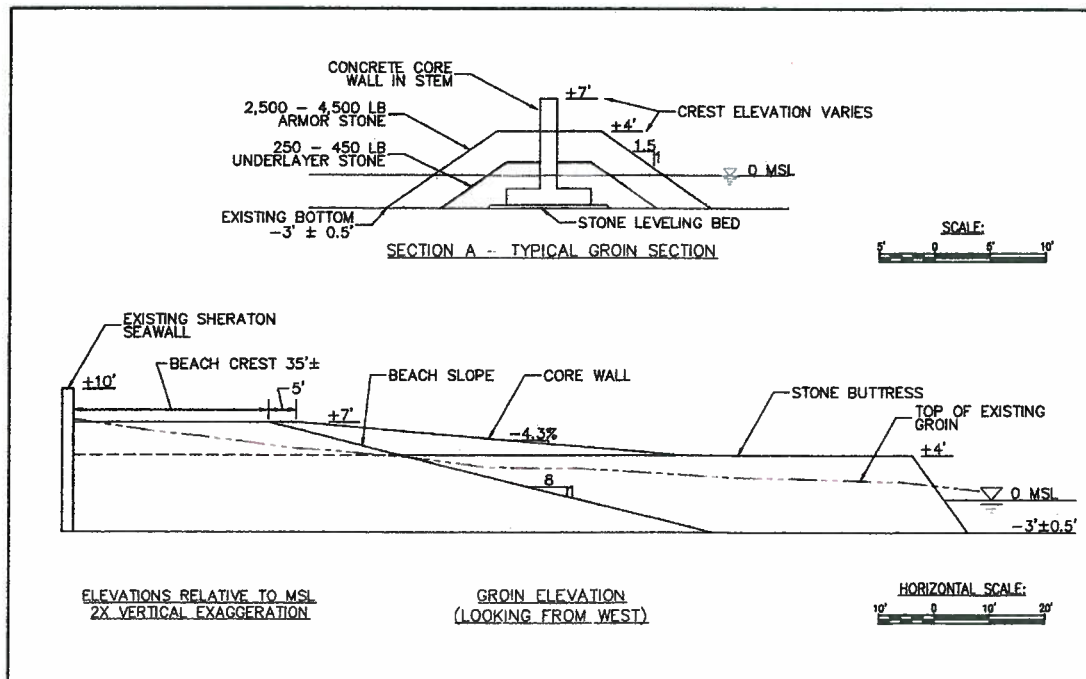

Groin section and elevation views

EXHIBIT 7



(a)

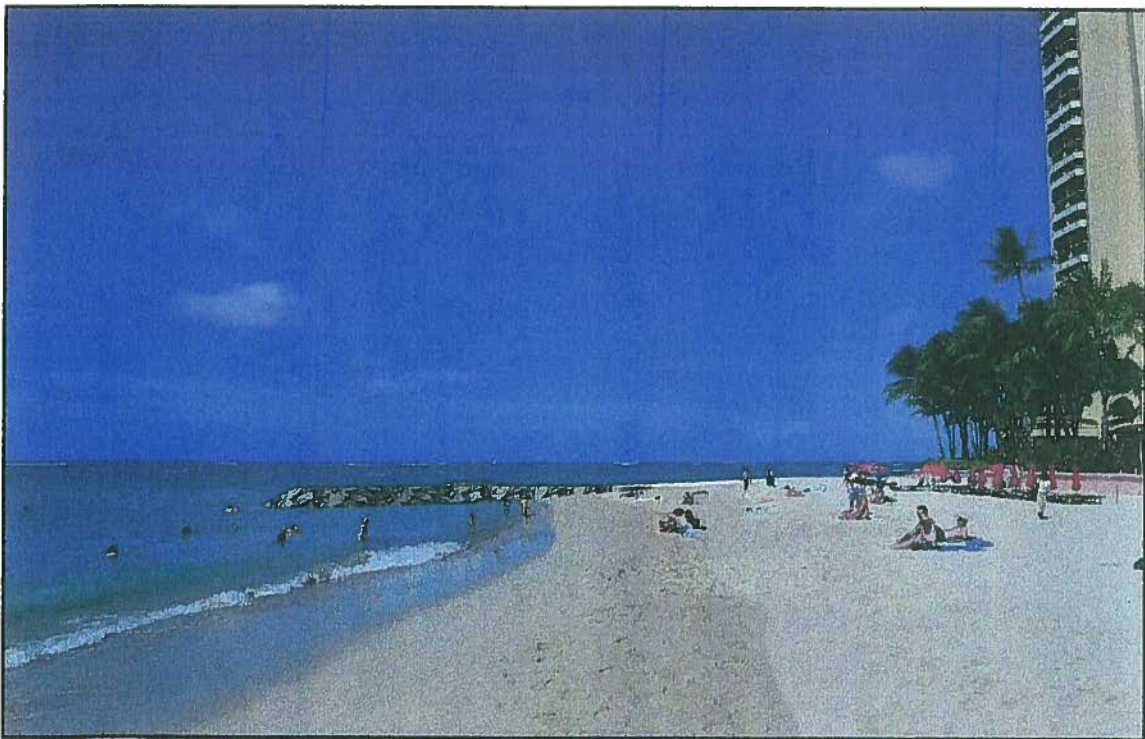

(b)

Project site looking west: (a) existing condition, (b) with 180-ft rock groin option

EXHIBIT 8



(a)



(b)

Project site looking offshore: (a) existing condition, (b) with 180-ft rock groin

EXHIBIT 9

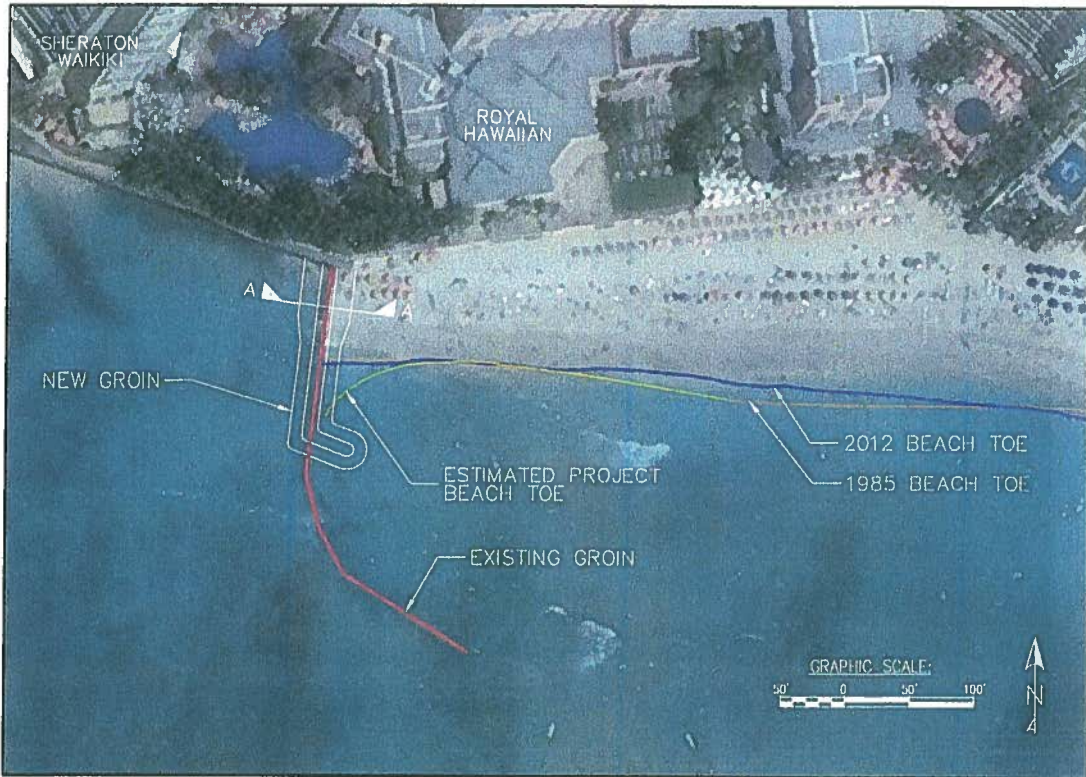

Adaptive Reuse groin plan view

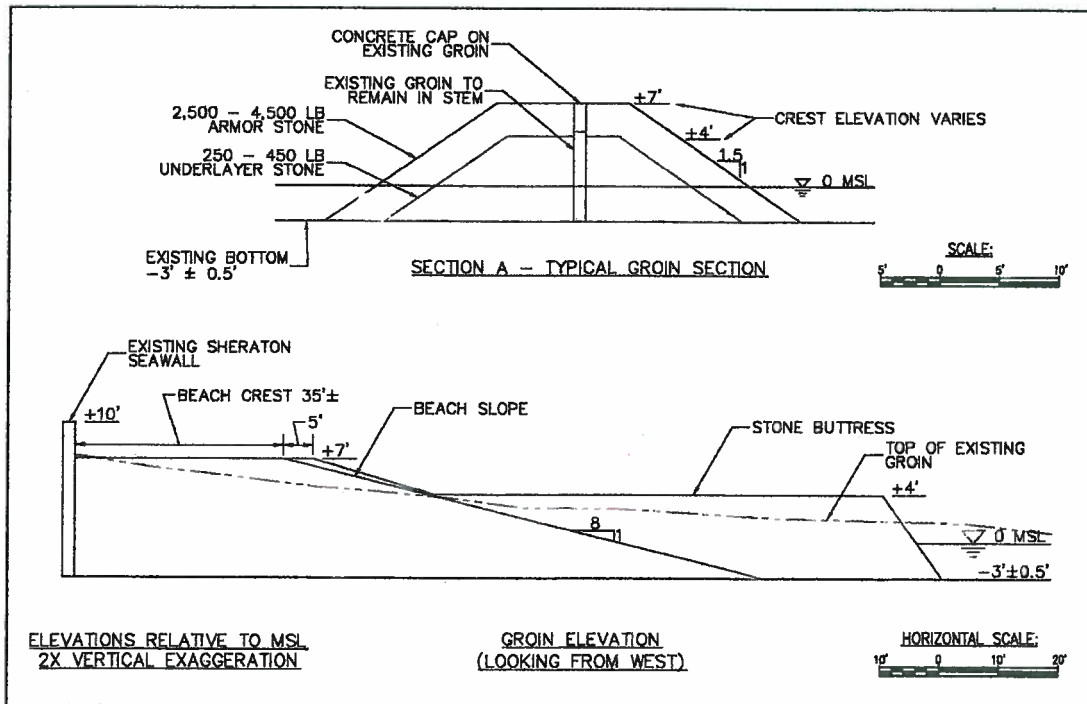

Adaptive Reuse groin section and elevation

EXHIBIT 10



Concrete wall groin plan view

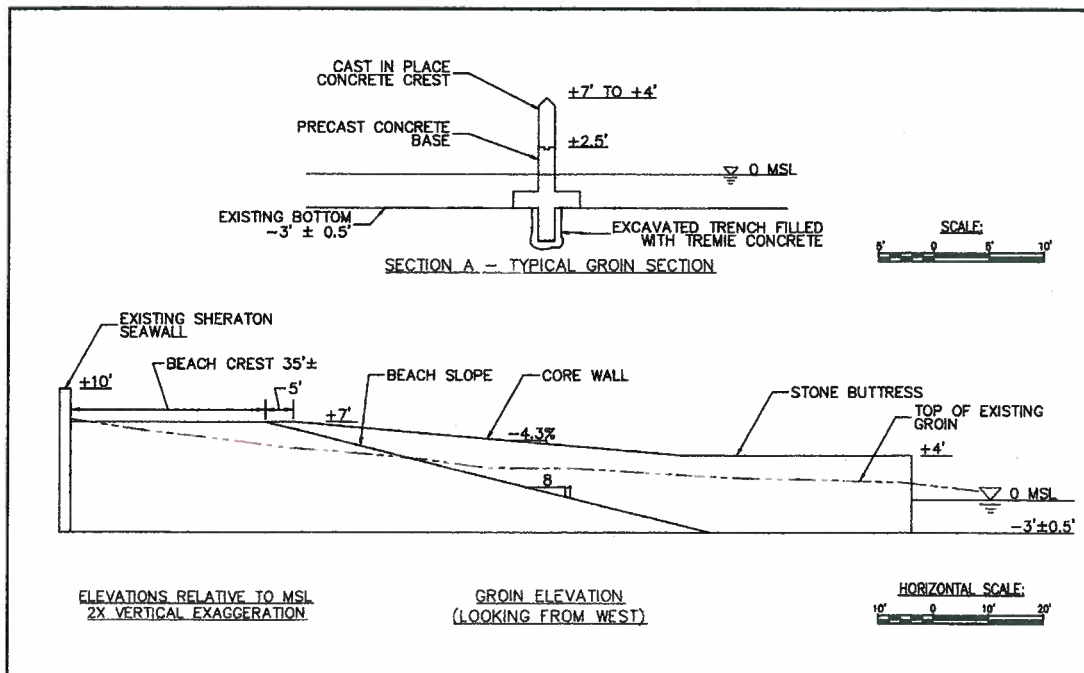

Concrete wall groin section and elevation

EXHIBIT 11



(a)



(b)

Project site looking offshore: (a) existing condition, (b) with 160-ft concrete wall groin

EXHIBIT 12



Construction access and staging areas