



STATE OF HAWAII
DEPARTMENT OF TRANSPORTATION
869 PUNCHBOWL STREET
HONOLULU, HAWAII 96813-5097

IN REPLY REFER TO:

Board of Land and
Natural Resources
State of Hawaii
Honolulu, Hawaii

ISSUANCE OF A REVOCABLE PERMIT FOR A VIP LOUNGE
HAWAIIAN AIRLINES, INC.
DANIEL K. INOUE INTERNATIONAL AIRPORT
TAX MAP KEY: (1) 1-1-003: 001 (PORTION)

OAHU

APPLICANT/LESSEE:

Hawaiian Airlines, Inc. (Hawaiian Airlines), whose business address is
3375 Koapaka Street, G350, Honolulu, Hawaii 96819.

LEGAL REFERENCE:

Section 171-55, Hawaii Revised Statutes (HRS), as amended.

LOCATION AND TAX MAP KEY:

Portion of Building 310, Third Level of Terminal 1, Daniel K. Inouye International
Airport (Airport), Island of Oahu, State of Hawaii, identified by
Tax Map Key: 1st Division, 1-1-003: 001 (Portion).

AREA:

Building/Room No. 310-312, consisting of an area of approximately 372 square feet;
Building/Room No. 310-351B, consisting of an area of approximately 1,605 square feet;
Building/Room No. 310-310, consisting of an area of approximately 3,427 square feet; and
Building/Room No. 310-351A, consisting of an area of approximately 819 square feet,
as shown and delineated on the attached map labeled Exhibit "A".

ZONING:

State Land Use District: Urban
City and County of Honolulu: I-2 (Industrial)

ITEM M-5

LAND TITLE STATUS:

Section 5(a) lands of the Hawaii Admissions Act: Non-ceded
DHHL 30% entitlement lands pursuant to the Hawaii State Constitution: YES ___ NO X

CURRENT USE STATUS:

Land presently encumbered by Governor’s Executive Order No. 3201, dated June 8, 1983, setting aside 3,152.177 acres designated as the Airport under the control and management of the State of Hawaii, Department of Transportation, Airports, for Airport Purposes.

CHARACTER OF USE:

VIP Lounge for its Signatory Airline Carrier Operations at the Airport.

COMMENCEMENT DATE:

Upon complete execution of the revocable permit.

MONTHLY RENTAL:

\$44,292.86 (as determined from the Airports Signatory Carriers Rates and Charges, Hawaii Airports System, effective July 1, 2023).

The Airports Signatory Carriers Rates and Charges, Hawaii Airports System for Fiscal Year 2024 is \$125.18 per square foot, per annum.

SECURITY DEPOSIT:

\$132,878.58, or three (3) times the monthly rent in effect.

DCCA VERIFICATION:

Place of business registration confirmed:	YES <u>X</u>	NO ___
Registered business name confirmed:	YES <u>X</u>	NO ___
Good standing confirmed:	YES <u>X</u>	NO ___

CHAPTER 343, HRS - ENVIRONMENTAL ASSESSMENT:

The environmental impacts of the proposed action to the subject land area are covered by the Honolulu International Airport Master Plan Update and Noise Compatibility Program Environmental Assessment (EA), State Project No. AO1011-03. The EA is a joint State and Federal document, dated September 1989 and published in the October 23, 1989 issue of the OEQC Bulletin. Accordingly, relevant mitigation from the EA and DOTA environmental best management practice will address minimal impacts from this action.

BLNR – ISSUANCE OF A REVOCABLE PERMIT FOR A VIP LOUNGE
HAWAIIAN AIRLINES, INC.

Page 3

REMARKS:

In accordance with Section 171-55, HRS, relating to Permits, the Department of Transportation proposes to issue a month-to-month revocable permit to Hawaiian Airlines for a VIP Lounge as part of its Signatory Airline Carrier Operations at the Airport.

RECOMMENDATION:

Based on this submittal, and testimony and facts presented, the Department of Transportation recommends the Board finds that approving the issuance of a month-to-month Revocable Permit to Hawaiian Airlines, including its conditions and rent, will serve the best interests of the State.

Respectfully submitted,



EDWIN H. SNIFFEN
Director of Transportation

APPROVED FOR SUBMITTAL:



DAWN N. S. CHANG
Chairperson
Board of Land and Natural Resources

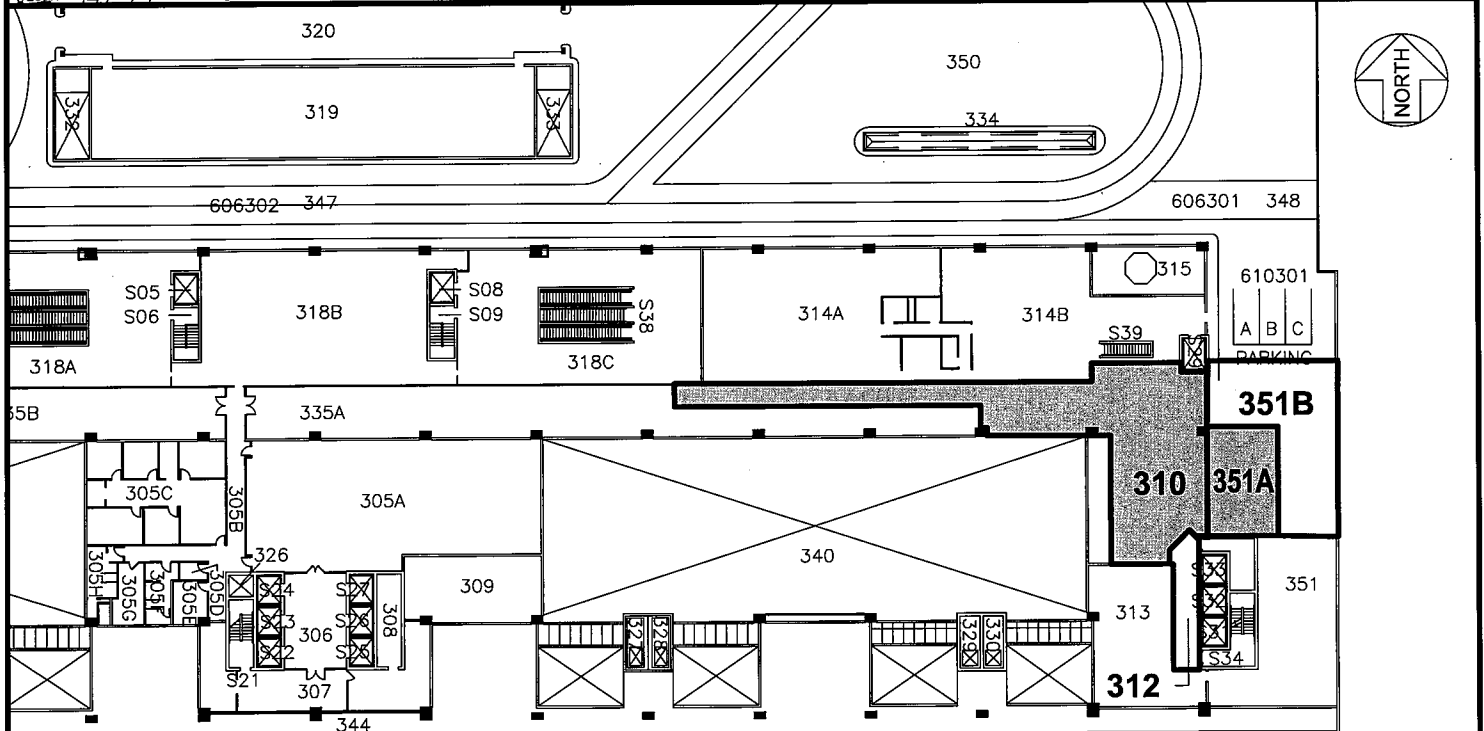
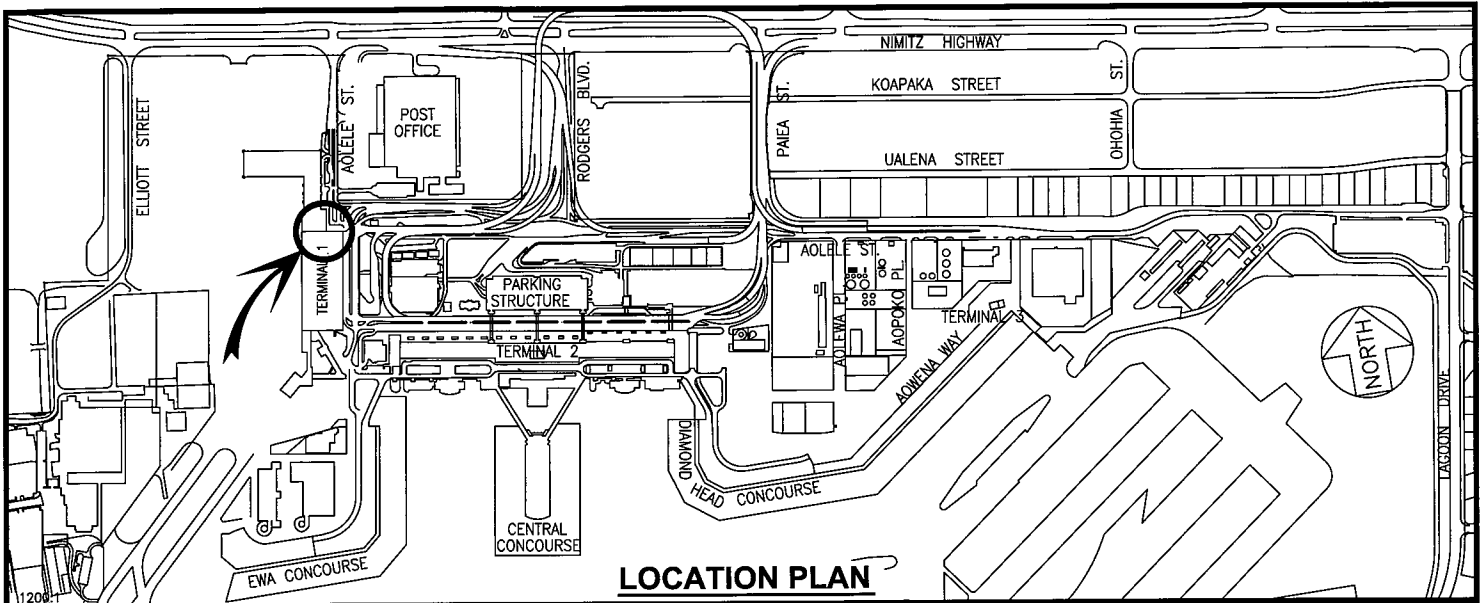

BLDG 310

BLDG/ROOM	SQ. FT.
310 312	372
310 351B	1,605

BLDG/ROOM	SQ. FT.
310 310	3,427
310 351A	819

SCALE: 1" = 60'

RP-9459

DATE: JUNE 2023

EXHIBIT: **A**



AIRPORTS

HAWAIIAN AIRLINES, INC.

BUILDING 310
TERMINAL 1
THIRD LEVEL

310310
310112
310351A
310351B

DANIEL K. INOUE INTERNATIONAL AIRPORT