

**State of Hawaii**  
**DEPARTMENT OF LAND AND NATURAL RESOURCES**  
**Engineering Division**  
**Honolulu, Hawaii 96813**

January 12, 2024

**Board of Land and Natural Resources**  
**State of Hawaii**  
**Honolulu, Hawaii**

**Authorize the Approval and Issuance of Dam Safety Permit P93 submitted by the  
Department of Hawaiian Homelands to Remove the Field 1 Kealia Reservoir  
(KA-0067), Anahola, Kauai, TMK (4)4-7-002:004**

The Engineering Division (Division) recommends approval of the subject Dam Safety permit application and authorization for the Chairperson to issue Dam Safety Permit No. P93 with stipulated terms and conditions for the Field 1 Kealia Reservoir breach project, pursuant to Hawaii Revised Statutes Chapter 179D and current Administrative Rules.

**Summary of Request**

Application for a Dam Safety Permit to breach the Field 1 Kealia Reservoir (KA-0067), which will de-regulate the dam and remove it from jurisdictional oversight of the Department of Land and Natural Resource (Department). (See Exhibit 1.)

**Background**

Field 1 Kealia Reservoir is located southwest of the community of Anahola Kauai County, Hawaii. The dam was built in the 1920s for agricultural irrigation but is currently kept empty through an always open outlet. The reservoir is a round shaped area that if it was full would hold 105 acre-ft or 34.2 million gallons and have a surface area is 4.5 acres. The reservoir is fed via Kaneha Ditch and the watershed area. The dam is in UNSATISFACTORY condition meaning a dam safety deficiency is recognized that requires immediate or emergency remedial action for problem resolution. Additional information on the physical characteristics of the dam is provided in the dam safety overview summary in Exhibit 2.

**Description**

The owners propose to remove the Field 1 Kealia Reservoir structure by grading a channel in the earthen embankment where the current outlet is located. The breach will consist of a 100-foot-wide trapezoidal channel with a benched slope varying from approximately 9 to 33-degree slopes. The excavated trapezoid will be covered with erosion control fabric. Once the excavation is done, the reservoir should no longer store water, removing any safety hazards, and the flow of water would be returned to approximately its original state. See Exhibit 3 for selected plan sheets.

### **Hawaii Revised Statutes Chapter 343- Environmental Assessment**

The State of Hawaii, Department of Hawaiian Homelands (DHHL) conducted an HRS-343 environmental assessment evaluation for the project and concluded the proposed action is exempt from the preparation of an environment assessment and will have minimal or no significant impact on the environment. Removal allows natural drainage through the existing reservoir sites, restoring natural water flow. (See Exhibit 4)

### **Hawaii Revised Statutes Chapter 6E-8 Historic Preservation Review**

The Division consulted with the State Historic Preservation Division (SHPD) for compliance with Chapter 6E-8 requirements. SHPD reviewed the proposed project, designated as SHPD Project No 2016PR22703, Decommission of Kealia Field No. 1 Reservoir and Upper Anahola Reservoir and concluded that SHPD concurs with a determination of Effect, and that the mitigation of completing an Historic American Engineer Record (HAER) No HI-135 which have already been submitted as sufficient mitigation. SHPD also requested that a State Inventory of Historic Places (SIHP) request be submitted. They indicated that the SIHP requests can be completed concurrently with the commencing of proposed work to decommission the two subject reservoirs. (See Exhibit 5 for SHPD's letter)

### **Agency Consultation**

The Division distributed notices to various agencies for their comments on this application. A brief summary of responses is included in Exhibit 6. The Commission on Water Resource Management confirmed the proposed work will not require a stream channel alteration permit.

### **Ka Pa'akai Analysis**

In consultation with Aha Moku, a Ka Pa'akai Pre-Assessment analysis was conducted of the proposed project, and it was determined the project will not impact Native Hawaiian customary traditional and cultural resources or practices. Aha Moku confirmed a more detailed Ka Pa'akai Consultation Assessment is not required.

### **Remarks**

The applicant/owner, DHHL completed and submitted to the Division a basis of design, plans, and other applicable studies needed. The Division has reviewed the documents and concluded it is sufficient for its intended purposes. Staff recommends approval of this permit application with the Dam Safety General Permit Conditions. (See Exhibit 7.)

**Recommendation**

1. Authorize the Chairperson to issue a Dam Safety Permit No. P93 for the removal of the Field 1 Kealia Reservoir (KA-0067), subject to such other terms and conditions as may be prescribed by the Chairperson to best serve the interests of the State.
2. Authorize the Chairperson to oversee performance of the permitted work and take appropriate action including, but not limited to, amending the permit, issuing fines and/or revoking the permit, if necessary.

Respectfully submitted,



CARTY S. CHANG  
Chief Engineer

APPROVED FOR SUBMITTAL:



Dawn N.S. Chang, Chairperson  
Board of Land and Natural Resources

- EXHIBIT 1 – Permit Application
- EXHIBIT 2 – Dam Safety Overview
- EXHIBIT 3 – Selected Plan Sheets
- EXHIBIT 4 – HRS 343 Analysis
- EXHIBIT 5 – SHPD Letter
- EXHIBIT 6 – Agency Consultation Summary
- EXHIBIT 7 – Dam Safety General Permit Conditions

**APPLICATION FOR APPROVAL OF PLANS AND SPECIFICATIONS FOR THE  
CONSTRUCTION, ENLARGEMENT, REPAIR, ALTERATION, OR REMOVAL OF  
DAMS IN THE STATE OF HAWAII**

**Introduction**

The Department of Land and Natural Resources (DLNR) Engineering Division administers the State Dam and Reservoir Program as authorized under Hawaii Revised Statutes Chapter 179D (HRS) and Hawaii Administrative Rules Title 13, Department of Land and Natural Resources, Sub-Title 7 – Water and Land Development, Chapter 190.1 – Dams and Reservoirs, (HAR). Requirements for obtaining an approval for the construction, enlargement, repair, alteration, or removal of dams and reservoirs are derived from the (HRS) and Hawaii Administrative Rules (HAR) and the steps for obtaining a dam safety permit are outlined in this application form. Any omissions or errors in this document do not relieve the Applicant from complying with applicable sections of the HAR.

All applications should be addressed to:

Chairperson, Board of Land and Natural Resources  
Department of Land and Natural Resources  
Engineering Division  
P.O. Box 373  
Honolulu, Hawaii 96809  
Telephone: (808) 587-0230

**Instructions**

An Applicant is encouraged to contact the Department if they are interested in a pre-application meeting. The pre-application meeting allows for discussion of the Applicants conceptual plan and the requirements of the Board for specific applications and gives the Applicant an opportunity to ask questions.

A separate project dam safety permit application form shall be used for each dam structure. All information on the application form should be typed or printed. If a specific item does not apply it should be marked NA (not applicable). All owners of the facility shall sign an “Owners Signature” page for this site and project.

The Department shall accept and take action on applications only if the fee for the application is paid. The fee is based upon two percent of the total project costs associated with the design and construction of the dam and appurtenant works as in accordance with Chapter 13-190.1-50.

Review steps:

1. Administrative completeness review
2. Permit technical review
3. Approval by Board of Land and Natural Resources
4. Issuance of Permit

Any questions pertaining to completion of this form should be directed to the Engineering Division, Dam Safety Program at (808) 587-0254.

**Hawaii Dam and Reservoir Safety Program  
DAM SAFETY PERMIT**

Dam Name: \_\_\_\_\_ Project Type: Removal

Field 1 Kealia Reservoir

**DAM SAFETY PERMIT APPLICATION**

**FORM**

Fill in the following information for the specified dam safety permit project. One application shall be used for each dam or reservoir structure.

<b>Project Information</b>	<i>Application Date</i>	08/30/2023
	<i>Applicant Name (Attachment 1)</i>	Department of Hawaiian Home Lands
Dam Name	Field 1 Kealia Reservoir	
Dam ID No. (State) (if New Dam enter N/A)	KA-0067	
Type of Project (check one)	<input type="checkbox"/> New Construction <input type="checkbox"/> Improvement (repair/rehabilitation/alteration) <input type="checkbox"/> Reduction (alteration to below regulatory jurisdiction) <input checked="" type="checkbox"/> Removal (breach, no pond)	
Dam/Reservoir Location (City)	Anahola, Kauai	
Dam/Reservoir Location (Latitude/Longitude)	22 07'48" N, 159 21'07" W	
TMK(s)	(4)4-7-002:004	
Island/County	Kauai	
State Land Use District (check all applicable)	<input type="checkbox"/> x Agriculture <input type="checkbox"/> Rural <input type="checkbox"/> Urban <input type="checkbox"/> Conservation	

<b>Application Package</b>	<b>Included (Y/N)</b>
1. Dam Safety Permit Application Form (with each owner's signature page) [Ref. 13-190.1-20(d)(1)]	Y
2. Design Report(s) [Ref. 13-190.1-20(d)(2)]	Y
3. Documentation for compliance with Chapter 343 Environmental Review	Y
4. Documentation for compliance with State Historic Preservation Division (SHPD) See SHPD website for HRS 6E Intake form to be submitted with backup documentation and determination. Government entities shall complete the 6E-08 review. ( <a href="http://dlnr.Hawaii.gov/shpd/review-compliance/forms/">http://dlnr.Hawaii.gov/shpd/review-compliance/forms/</a> )	Y
5. Construction Plans (2 sets) [Ref. 13-190.1-20(d)(3)]	Y
6. Construction Specifications (2 sets) [Ref. 13-190.1-20(d)(3)]	Y
7. Construction Quality Assurance Plan [Ref. 13-190.1-20(d)(4)]	Y
8. Detailed Cost Estimate [Ref. 13-190.1-20(d)(5)]	Y
9. Filing fee calculation [Ref. 13-190.1-20(d)(6)]	Y
10. Filing fee (check) [Ref. 13-190.1-20(d)(6)]	Y
11. Other Supporting Documents	Y
12. Electronic copy of all of the above on CD/DVD/USB flash drive/other	Y

**Hawaii Dam and Reservoir Safety Program  
DAM SAFETY PERMIT**

Dam Name: \_\_\_\_\_ Project Type: Removal

Field 1 Kealia Reservoir

<b>Technical Information</b>	
Drainage Area (sq. miles/acres)	76.8 acres
Type of Structure (Earthen/Concrete, etc.)	Earthen
Size Classification of Dam	Small
Hazard Classification	High Hazard
Purpose of Structure (Water supply, irrigation, recreation, real estate development, etc...)	Irrigation
Maximum Capacity (existing volume)	105 acre-feet
Maximum Capacity (revised volume after project completed)	0
Year completed/last modified	Year completed is 1920

**Description of Work to be performed** (describe construction work to be done on dam and reservoir facility)

Dam will be removed. No impoundment or water storage capability remains.

**Anticipated effect of proposed structure on natural environment:**

Restore watershed to original condition. Remove water storage capability of existing dam.

List all parties who share ownership of the parcels where the dam and reservoir are located and identify their interest in the property. All owners herein listed below shall sign **Attachment 2 – Owner Signature** and concur with the work proposed within this application by the applicant.

<b>Owner Information</b>	
<b><u>Owner 1 Name:</u></b> State of Hawaii, Dept. of Hawaiian Home Lands	TMK: (4)4-7-002:004
<b><u>Owner 2 Name:</u></b> Company:	TMK:
<b><u>Owner 3 Name:</u></b> Company:	TMK:
<b><u>Owner 4 Name:</u></b> Company:	TMK:

**Hawaii Dam and Reservoir Safety Program  
DAM SAFETY PERMIT**

Dam Name: \_\_\_\_\_ Project Type: Removal

Field 1 Kealia Reservoir

**Attachment 1**  
**APPLICANT CONTACT INFORMATION**

<b>Applicant Information (primary contact for Dam Safety Permit process)</b>	
Applicant Contact Name	Stewart Matsunaga
Firm/Company	State of Hawaii, Department of Hawaiian Home Lands Land Management Division
Mailing Address	P.O. Box 1879, Honolulu, HI 96805
Telephone	808-620-9278
Fax	808-620-9299
Email	stewart.t.matsunaga@hawaii.gov

I, Stewart Matsunaga, the applicant, hereby certify that the information herein is  
(print name)  
true and factual to the best of my knowledge. Signing below indicates that the applicant understands that, if the permit requested is granted by the Board of Land and Natural Resources, the proposed work is to be initiated and completed within five (5) years of the approval date, unless specifically permitted in the approved permit terms and conditions.

  
Stewart Matsunaga (Oct 27, 2023 17:13 HST)  
Applicant Signature

Date: Oct 27, 2023

Administrator, Land Development Division  
Applicant Title

**ENGINEER CONTACT INFORMATION**

<b>Licensed Engineer Contact Information</b>	
Registered Hawaii Professional Engineer	Eric H. Tamashiro, P.E.
Registration No.	9787-C
Firm/Company	Bowers + Kubota Consulting, Inc.
Mailing Address	2153 N. King St. Ste. 200 Honolulu, HI 96819
Telephone	808-521-5361
Mobile/Other	
Fax	
Email	etamashiro@bowersandkubota.com

**Hawaii Dam and Reservoir Safety Program  
DAM SAFETY PERMIT**

Dam Name: \_\_\_\_\_ Project Type: Removal

Field 1 Kealia Reservoir

**Attachment 2**  
**OWNER INFORMATION/SIGNATURE**

A separate signature page is required for each and all owners of the dam and reservoir for the subject project. The Owner herein listed below concurs with the work proposed within this application by the applicant and by signing hereto, the owner of the land extends to the Board of Land and Natural Resources, and its designated representatives, a right-of-entry onto the project site to conduct any investigations or inspections required in compliance with the provisions of Chapter 13-190.1, Hawaii Administrative Rules. (Submit copies of this sheet for each owner)

<b>Owner Information</b>	
Owner Contact Name	Kali Watson, Chairman
Firm/Company	State of Hawaii, Department of Hawaiian Home Lands
Mailing Address	P.O. Box 1879, Honolulu, HI 96805
Telephone	808-620-9510
Mobile/Other	
Fax	808-620-9529
Email	Kali.watson@hawaii.gov
TMK for dam/reservoir property	(4)4-7-004:002

**Owner Signature**

Kali Watson, Chairman, Hawaiian Homes Commission

\_\_\_\_\_  
Print Name of Owner



\_\_\_\_\_  
Signature of Owner

Oct 30, 2023

\_\_\_\_\_  
Date



**Hawaii Dam and Reservoir Safety Program  
DAM SAFETY PERMIT**

Dam Name: \_\_\_\_\_ Project Type: Removal

Field 1 Kealia Reservoir

**Attachment 3**

**EEE REQUIREMENTS/FILING FEE CALCULATION**

Payment of the filing fee is required pursuant to HRS §179D-6 and §13-190.1-50 for all applications. The Department shall accept and take action on the following applications and filings only if the fee shown for the application or filing is paid at the time the application or filing is submitted. The fee is based upon two percent of the total project costs associated with construction of the dam and appurtenant works integral to the design and safe operation of the dam.

The applicant or owner shall submit with the application for construction, enlargement, alteration, repair, or removal a fee calculation sheet and the application fee in the amount equal to two per cent of the estimated cost of construction including engineering costs. The estimated cost of the construction, enlargement, alteration, repair, or removal shall include the cost of all labor and materials entering into the construction of the dam and appurtenant works or reservoir, the cost of preliminary investigations and surveys, the cost of the construction plans properly chargeable to the cost of the dam or reservoir, and any and all other items entering directly into the cost of the construction, enlargement, alteration, repair or removal. The costs of right-of-way, detached powerhouses, electrical generating machinery, and roads and railroads affording access to the dam or reservoir shall not be included among the items used in the determination of cost.

An application shall not be considered by the department until the application fee is received. In the event the actual cost exceeds the estimated cost by more than 15 percent, a further fee shall be required by the board before final approval and shall be two per cent of the amount the actual cost exceeded the estimated cost of the construction, enlargement, alteration, repair, or removal. No further fee shall be required, if such fee is to be computed at less than twenty dollars (\$20).

**FILING FEE CALCULATION**

Engineering costs (studies, plans, specifications, etc...)	<u>\$90,200.00</u>
Estimated Construction cost	<u>\$1,796,034.74</u>
Total estimated costs	<u>\$1,886,234.74</u>
Initial Application fee = 2% x Total estimated costs	<u>\$37,724.70</u>

**Hawaii Dam and Reservoir Safety Program  
DAM SAFETY PERMIT**

Dam Name: \_\_\_\_\_ Project Type: Removal  
Field 1 Kealia Reservoir

**CONDITIONS OF APPROVAL**

Construction work shall commence within five years of the date of the approved application. A licensed engineer in the State of Hawaii shall be in charge of the inspection of the construction.

One set of final plans and specifications with the County approval (signature) shall be submitted to the Department prior to the start of the work.

The Department shall be notified five (5) calendar days prior to the commencement of the construction, and a construction schedule shall be provided, which includes the notice to proceed date and estimated project duration.

Changes and/or modifications to the plans shall be sent to DLNR Dam Safety Program in the form of shop drawings and/or plans that are approved and stamped by a licensed engineer. Changes and/or modifications shall not be implemented until approved by DLNR Dam Safety Program.

The owner or owner's representative shall submit a copy of the dam safety application and the plans and specifications of the proposed improvements to the County Engineer of the County for which the dam resides for compliance with County codes.

This permit does not relieve the owner or owner's representative of their obligations to comply with all applicable Federal, State, and County regulations. These may include but may not be limited to:

- **National Pollution Discharge Elimination System (NPDES) Permit** – Department of Health (DOH), Environmental Management Division, Clean Water Branch (CWB), Engineering Section.
- **US Army Corps of Engineers Permits (404 Permit)** – USACE, DOH, CWB, Engineering Section
- **Threatened and Endangered Species Review Request** – U.S. Fish and Wildlife Service
- **'No Effects' Letter** – DLNR, State Historic Preservation Division (SHPD)
- **DLNR Stream Channel Permit** – DLNR, Commission on Water Resource Management
- **DOH 401 Permit** – DOH, CWB, Engineering Section
- **Grading Permit** – County, Department of Public Works (DPW), Engineering Division
- **Grubbing Permit** – County, Department of Public Works (DPW), Engineering Division
- **Work Within the County Right-of-Way** – County, Department of Public Works (DPW), Engineering Division
- **Stockpiling Permit** – County, Department of Public Works (DPW), Engineering Division
- **Private Waterline Permit** – County, Department of Public Works (DPW), Engineering Division
- **Building Permit** – County, Department of Public Works (DPW), Building Division
- **Planning Approval** – County, Planning Division
- **Community Noise Permit** – State of Hawaii, DOH, Environmental Management Division, Indoor and Radiological (IRH) Branch







Aerial Photo (07/12/2007)

### 4. Reservoir

a. Normal Storage	80 ac-ft / 26 MG
b. Maximum Storage	105 ac-ft / 34 MG
c. Surface Area	4.5 acres

### 5. Primary Spillway

a. Minimum Width	10 ft
b. Length	12 ft
c. Type	Channel
d. Protection	Grouted Riprap
e. Maximum Discharge	

### 6. Primary Outlet Works

a. Works Type	Uncontrolled
b. Maximum Discharge	
c. Size	24
d. Control Description	

### 7. Embankment

a. Type of Dam	Earthen
b. Minimum Crest Width	5 ft
c. Upstream Slope Grade	27° / 2:1
d. Upstream Slope Protection	Vegetation
e. Downstream Slope Grade	35° / 1.4:1
f. Downstream Slope Protection	Vegetation
g. Dam Height	29 ft
h. Dam Length	530 ft

### 8. Inflow Works

Type	Name	Controlled	Size
None Specified			



# DEPARTMENT OF HAWAIIAN HOME LANDS STATE OF HAWAI'I ANAHOLA RESERVOIRS IMPROVEMENT PROJECT

ANAHOLA, KAUA'I COUNTY, HAWAI'I  
TMK: (4) 4-7-002:004  
REMOVE KEĀLIA FIELD 1 DAM  
State ID: KA-0067

PREPARED BY:

**BK** BOWERS + KUBOTA CONSULTING  
Project Management • Planning • Architectural/Engineering Design • Construction Management  
94-408 Akoki Street, Suite 201-A  
WAIPAHU, HAWAI'I 96797  
PH: (808) 836-7787 / (808) 833-1841  
FAX: (808) 834-4833

PREPARED FOR:

DEPARTMENT OF HAWAIIAN  
HOME LANDS  
Hale Kalaniana'ole  
91-5420 Kapolei Parkway  
Kapolei, Hawaii 96707

## INDEX OF DRAWINGS

DWG. NO.	DESCRIPTION
C-000	TITLE SHEET, LOCATION MAP, VICINITY MAP, & INDEX OF DRAWINGS
C-100	GENERAL NOTES, LEGEND, & ABBREVIATIONS
C-501	EROSION & SEDIMENT CONTROL PLAN
C-502	GRADING PLAN
C-503	PROFILE
C-504	SECTION & DETAILS

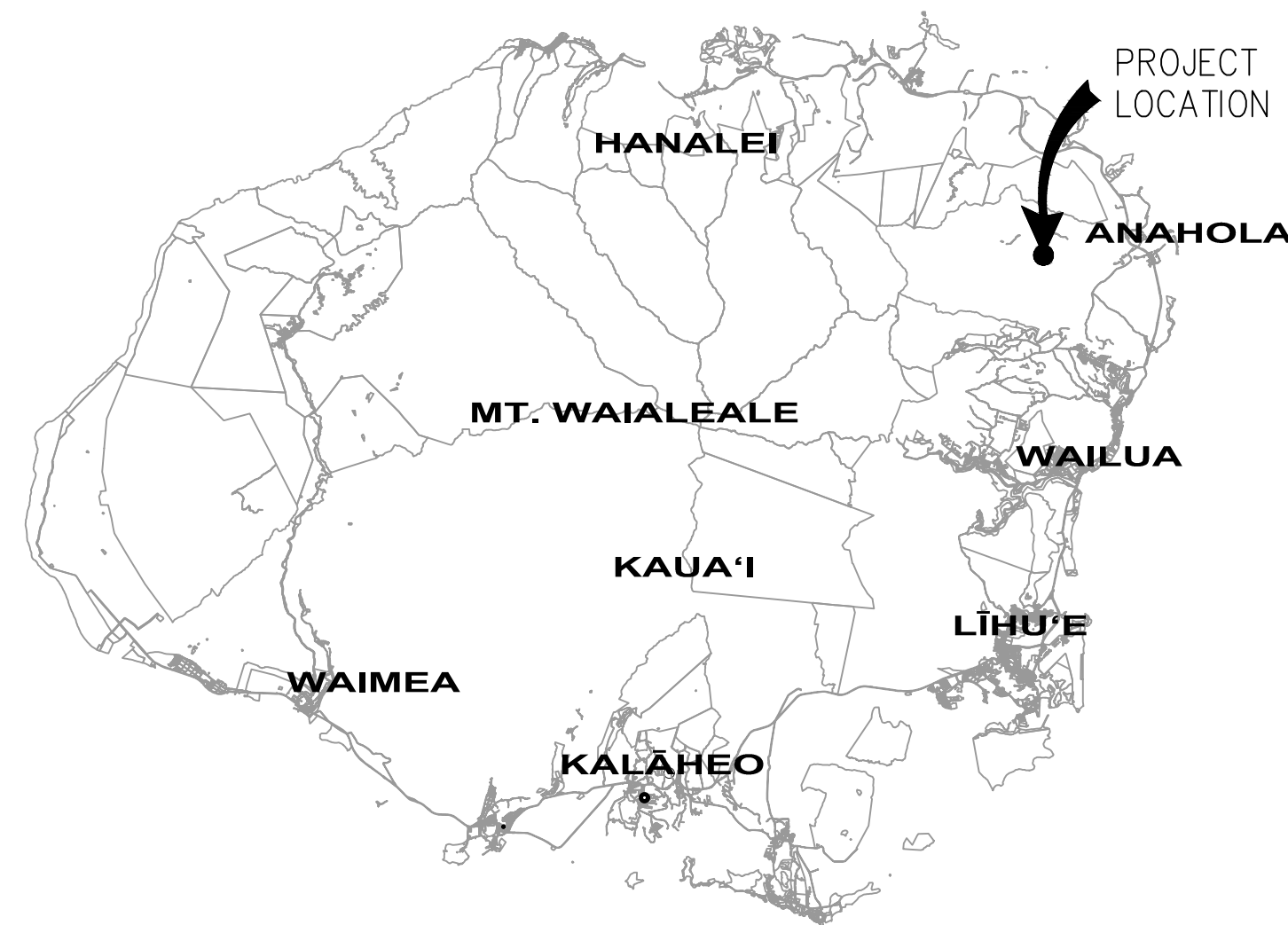

**LOCATION MAP**  
NOT TO SCALE

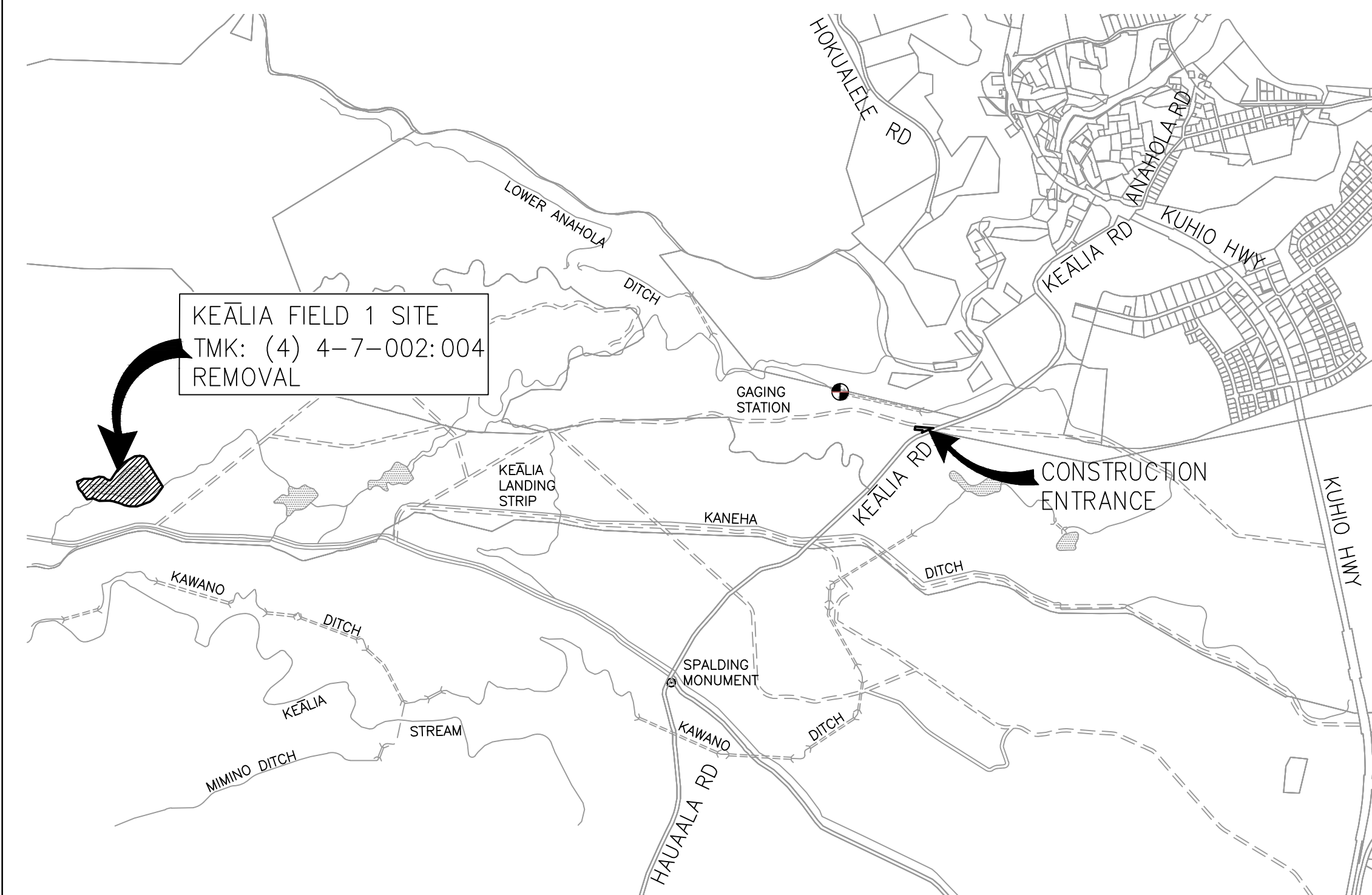

**VICINITY MAP**  
NOT TO SCALE

REVISION NO.	SYM.	DESCRIPTION	SHT. OF	DATE	APPROVED

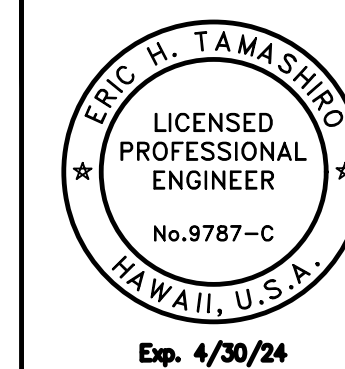

DEPARTMENT OF HAWAIIAN HOME LANDS  
STATE OF HAWAI'I  
**ANAHOLA RESERVOIRS IMPROVEMENT PROJECT**  
**REMOVE KEĀLIA FIELD - 1**  
Kaua'i County, Hawai'i

**TITLE SHEET**

DESIGNED BY: EHT		CHECKED BY: EHT		JOB NO. ----	DRAWING NO. C-000
DRAWN BY: LS		APPROVED BY:		DATE 08-24-2023	SHEET 1
SCALE: -				OF 6	SHTS.

THIS WORK WAS PREPARED BY ME OR UNDER MY SUPERVISION AND CONSTRUCTION OF THIS PROJECT WILL BE UNDER MY OBSERVATION.



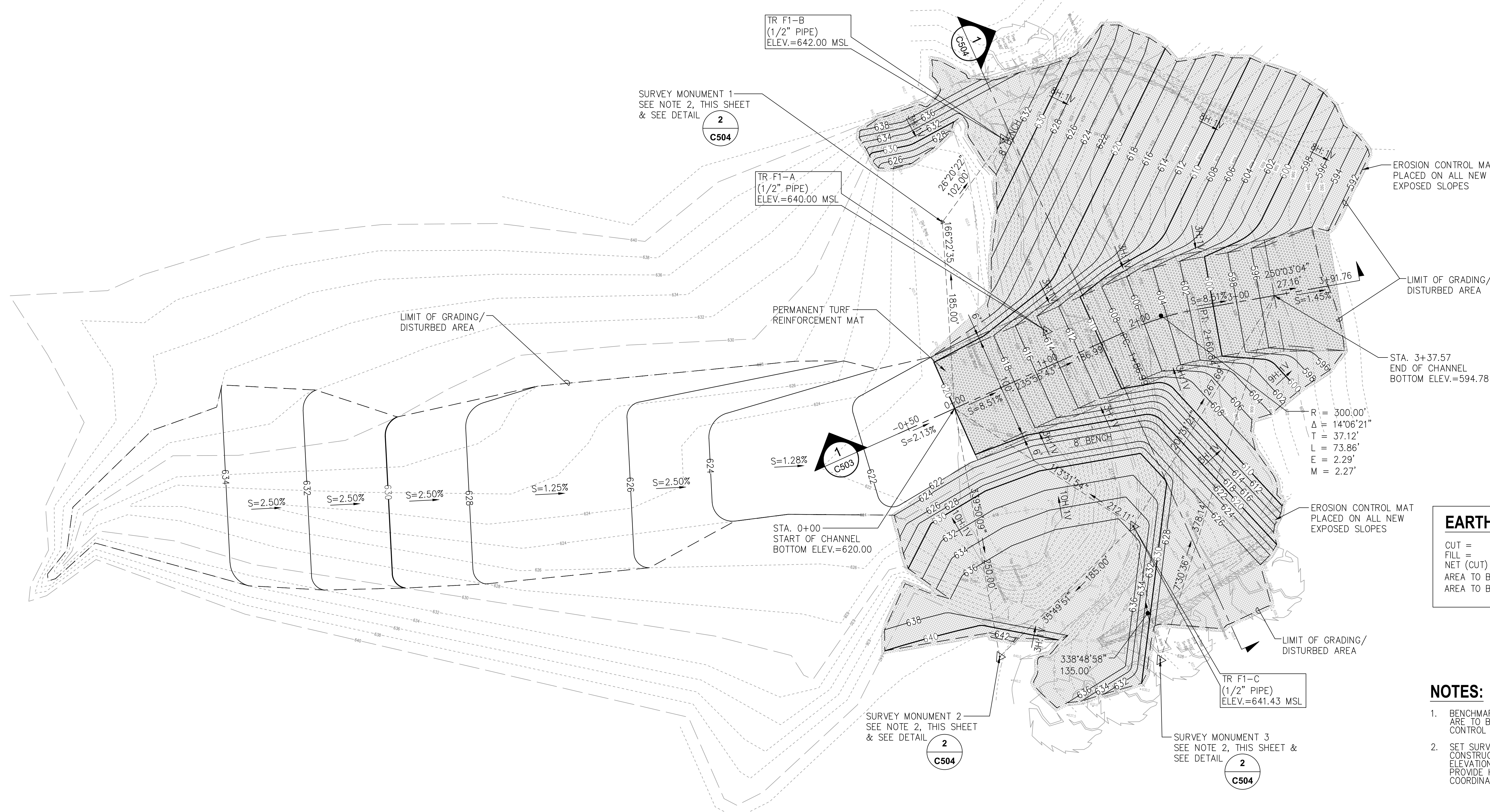
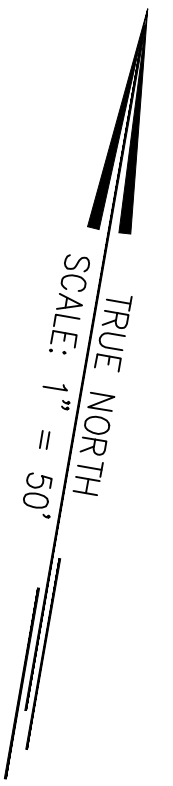

TR F1-B  
(1/2" PIPE)  
ELEV.=642.00 MSL

SURVEY MONUMENT 1  
SEE NOTE 2, THIS SHEET  
& SEE DETAIL

2  
C504

TR F1-A  
(1/2" PIPE)  
ELEV.=640.00 MSL

LIMIT OF GRADING/  
DISTURBED AREA

PERMANENT TURF  
REINFORCEMENT MAT

EROSION CONTROL MAT  
PLACED ON ALL NEW  
EXPOSED SLOPES

LIMIT OF GRADING/  
DISTURBED AREA

STA. 3+37.57  
END OF CHANNEL  
BOTTOM ELEV.=594.78

R = 300.00'  
Δ = 14°06'21"  
T = 37.12'  
L = 73.86'  
E = 2.29'  
M = 2.27'

EROSION CONTROL MAT  
PLACED ON ALL NEW  
EXPOSED SLOPES

**EARTHWORK QUANTITIES:**

CUT =	22,922 CY
FILL =	22,884 CY
NET (CUT) =	38 CY
AREA TO BE GRADED =	8.12 ACRES
AREA TO BE DISTURBED =	8.12 ACRES

S=1.28%  
S=2.13%  
S=8.51%

STA. 0+00  
START OF CHANNEL  
BOTTOM ELEV.=620.00

TR F1-C  
(1/2" PIPE)  
ELEV.=641.43 MSL

SURVEY MONUMENT 2  
SEE NOTE 2, THIS SHEET  
& SEE DETAIL

2  
C504

SURVEY MONUMENT 3  
SEE NOTE 2, THIS SHEET  
& SEE DETAIL

2  
C504

**NOTES:**

- BENCHMARKS TR F1-A, TR F1-B AND TR F1-C ARE TO BE USED FOR HORIZONTAL AND VERTICAL CONTROL POINTS IN ALL GRADING WORKS.
- SET SURVEY MONUMENT 1, 2 & 3 OFF THE CONSTRUCTION SITE. PROVIDE VERTICAL TIE-IN ELEVATION FOR ALL THREE SURVEY MONUMENTS. PROVIDE HORIZONTAL TIE-IN TO STATE COORDINATE SYSTEM NAD 83.

**SHEET LEGEND:**

- EROSION CONTROL MAT
- PERMANENT TURF REINFORCEMENT MAT
- LIMITS OF GRADING/DISTURBED AREA
- PROPOSED MAJOR CONTOUR
- PROPOSED MINOR CONTOUR

**GRAPHIC SCALE:**

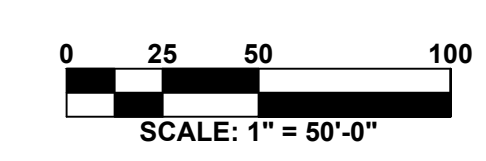

**GRADING PLAN**  
SCALE: 1"=50'-0"

1

REVISION NO.	SYM.	DESCRIPTION	SHT. OF	DATE	APPROVED

ERIC H. TAMASHIRO  
LICENSED PROFESSIONAL ENGINEER  
No. 9787-C  
HAWAII, U.S.A.  
Exp. 4/30/24

DEPARTMENT OF HAWAIIAN HOME LANDS  
STATE OF HAWAII

**ANAHOLA RESERVOIRS IMPROVEMENT PROJECT**

**REMOVE KEĀLIA FIELD - 1**

Kaua'i County, Hawai'i

**GRADING PLAN**

JOB NO. ---

DRAWING NO. C502

DESIGNED BY: EHT  
CHECKED BY: EHT

DRAWN BY: LS  
APPROVED BY: [Signature]

DATE: 08-25-2023

SCALE: 1" = 50'

SHEET 4 OF 6 SHTS.

19A7221.00 8/25/23



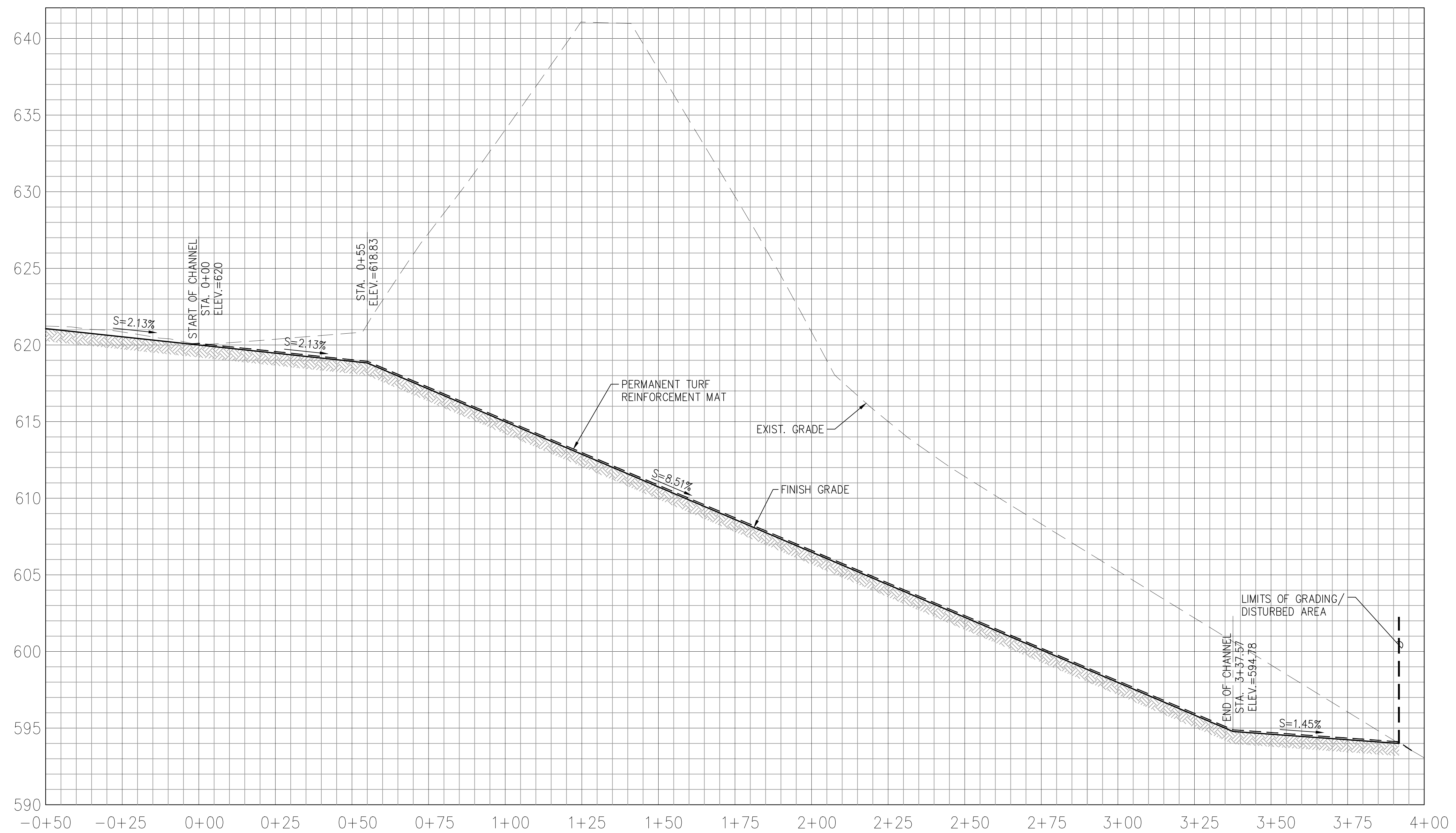

**PROFILE**  
 SCALE: HOR. 1"=20'-0"  
 VERT. 1"=4'-0"

1

**GRAPHIC SCALE:**

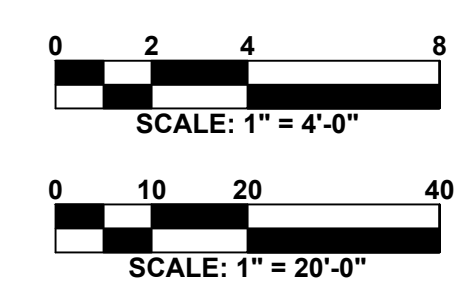

REVISION NO.	SYM.	DESCRIPTION	SHT. OF	DATE	APPROVED

Exp. 4/30/24

*E. H. Tamashiro*

THIS WORK WAS PREPARED BY ME OR UNDER MY SUPERVISION AND CONSTRUCTION OF THIS PROJECT WILL BE UNDER MY OBSERVATION.

**DEPARTMENT OF HAWAIIAN HOME LANDS**  
STATE OF HAWAII

**ANAHOLA RESERVOIRS IMPROVEMENT PROJECT**

**REMOVE KEĀLIA FIELD - 1**  
Kaua'i County, Hawai'i

**PROFILE**

**BOWERS + KUBOTA**

DESIGNED BY: EHT  
DRAWN BY: LS

CHECKED BY: EHT  
APPROVED BY:

JOB NO. ---  
DATE: 08-25-2023

DRAWING NO. C503  
SHEET 5  
SCALE: 1" = 20' H, 1" = 4' V

OF 6 SHTS.

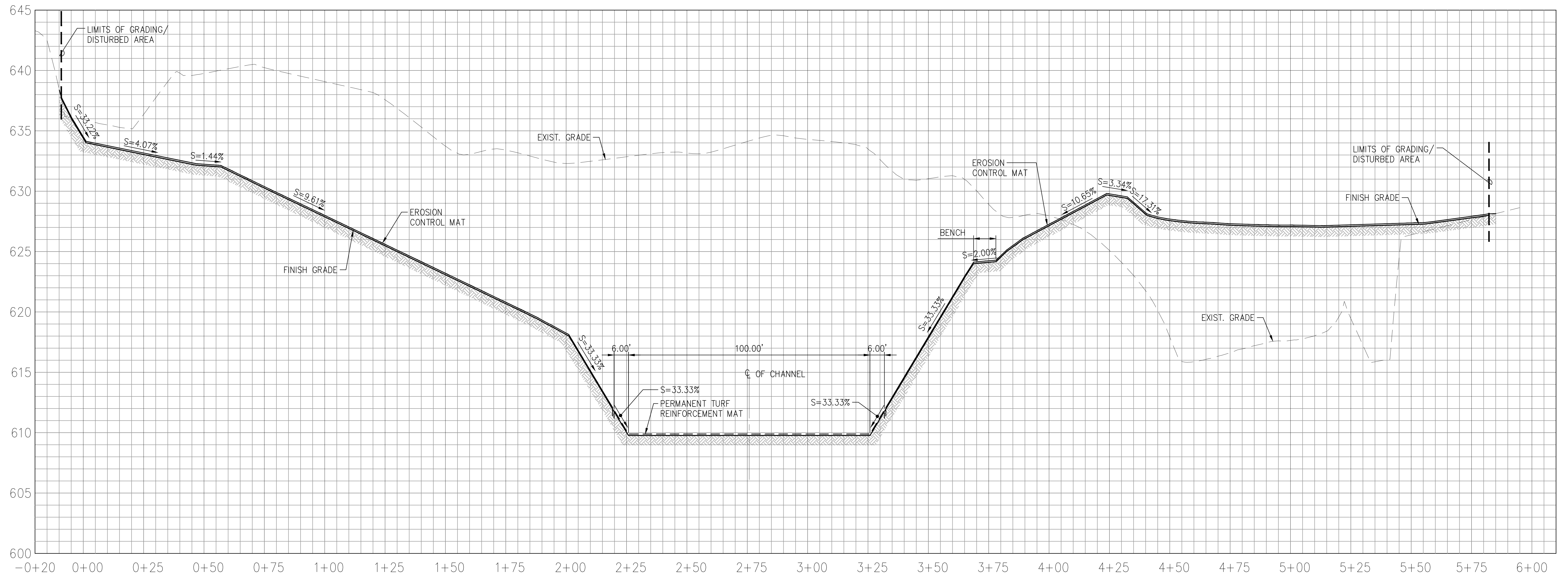

**SECTION**

SCALE: HOR. 1"=20'-0"  
VERT. 1"=4'-0"

1

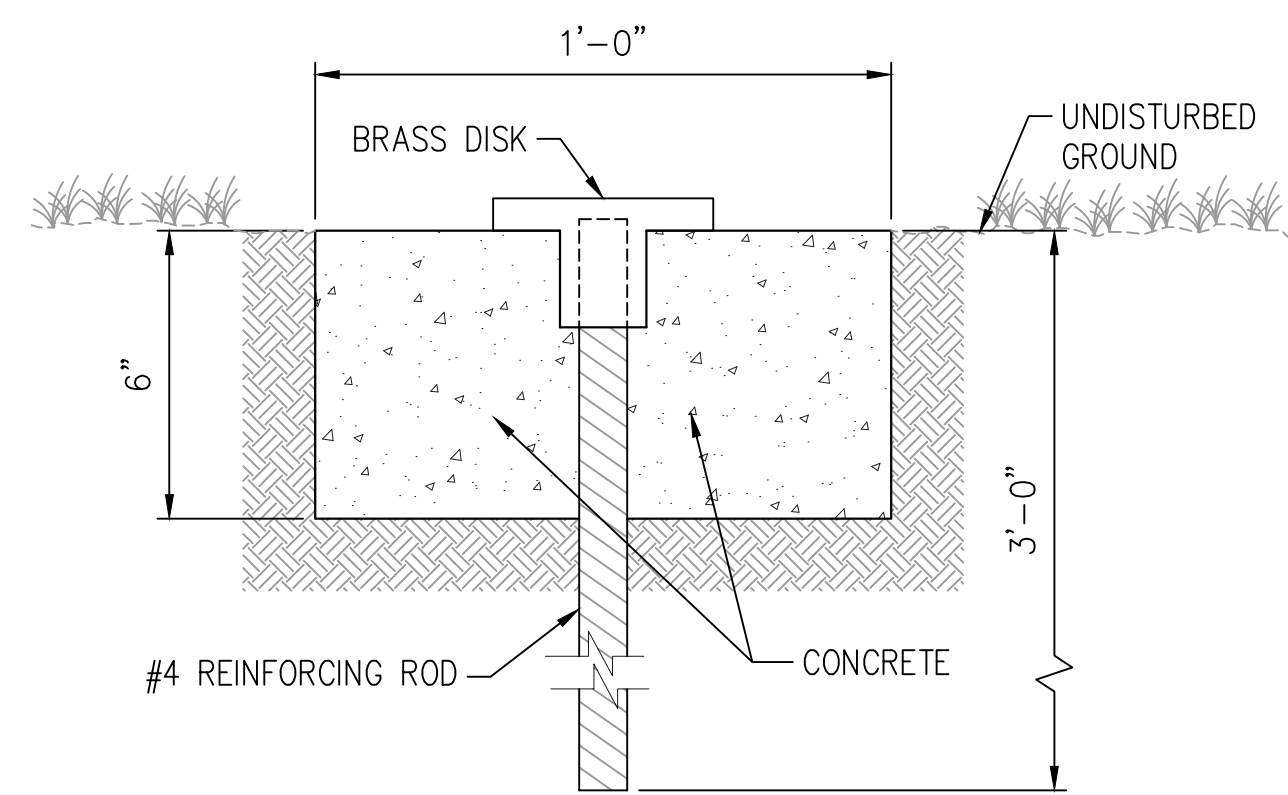

**SURVEY MONUMENT**

NOT TO SCALE

2

**GRAPHIC SCALE:**

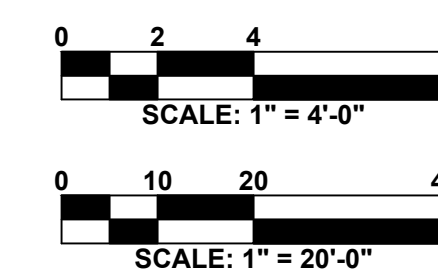

REVISION NO.	SYM.	DESCRIPTION	SHT. OF	DATE	APPROVED

	<b>DEPARTMENT OF HAWAIIAN HOME LANDS</b> STATE OF HAWAII		JOB NO. --- DRAWING NO. C504
	<b>ANAHOLA RESERVOIRS IMPROVEMENT PROJECT</b> REMOVE KEĀLIA FIELD - 1 Kaua'i County, Hawai'i		
<b>SECTION &amp; DETAIL</b>		DESIGNED BY: EHT CHECKED BY: EHT DRAWN BY: LS APPROVED BY:	DATE: 08-25-2023
SCALE: 1" = 20' H, 1" = 4' V		FILE _____ DRAW _____ FOLDER _____	THIS WORK WAS PREPARED BY ME OR UNDER MY SUPERVISION AND CONSTRUCTION OF THIS PROJECT WILL BE UNDER MY OBSERVATION.



**Dam Safety Program  
CHAPTER 343 ANALYSIS**

Exhibit 4

Dam Name: Kealia Field 1 and Upper Anahola Reservoirs  
Dam ID Number: KA-0067 and KA-0065  
Type of Project: Decommissioning  
Brief Description of Project: Removal of the existing embankment and dam appurtenances to allow natural drainage through the existing reservoir sites (DHHL reference file PO-22-163).  
TMK's: (4)4-7-004:002, (4)4-7-004:004

---

Reviewer Name: Malia Cox Date of Review: August 31, 2022  
Reviewer Title: Compliance Specialist  
Reviewer Company: Department of Hawaiian Home Lands

**TRIGGERS (HRS §343-5(a))**

Is there an "action" that triggers the need for an EA?

Action

An "action" is a program or project:

- Initiated by an agency
- Initiated by an "applicant"
- Any person who, pursuant to statute, ordinance, or rule, officially requests "approval" for a proposed action (discretionary consent required from an agency prior to actual implementation of an action, distinguished from a ministerial consent)
  - Statute
  - Ordinance
  - Rule

Triggers

- | Yes                                 | No                                  |  |
|-------------------------------------|-------------------------------------|--|
| <input checked="" type="checkbox"/> | <input type="checkbox"/>            | Use of state or county lands or funds  |
| <input type="checkbox"/>            | <input type="checkbox"/> N/A        | Use of conservation district lands (DHHL lands not subject to SLUD)  |
| <input type="checkbox"/>            | <input checked="" type="checkbox"/> | Use within shoreline setback area  |
| <input type="checkbox"/>            | <input checked="" type="checkbox"/> | Use of historic site designated on the National or Hawaii registers  |
| <input type="checkbox"/>            | <input checked="" type="checkbox"/> | Use of land in the Waikiki Special District  |
| <input type="checkbox"/>            | <input checked="" type="checkbox"/> | Amendment to county general plan which would result in designations other than agriculture, conservation, or preservation unless initiated by a county |
| <input type="checkbox"/>            | <input checked="" type="checkbox"/> | Reclassification of conservation lands by the Land Use Commission  |
| <input type="checkbox"/>            | <input checked="" type="checkbox"/> | Construction or modification of helicopter facilities that may affect conservation district lands, a shoreline setback area, or a historic site        |
| <input type="checkbox"/>            | <input checked="" type="checkbox"/> | Wastewater facilities, waste-to-energy facility, landfill, oil refinery, or power-generating facility  |

Triggers summary:

Is there a trigger? Yes  No

If Yes, **Go to Exemptions**

If No, Environmental Assessment is NOT required. **Go to Summary.**

**Dam Safety Program**  
**CHAPTER 343 ANALYSIS**

**EXEMPTIONS**

Two sources of exemptions: exemption lists or exemptions contained in HAR §11-200.1-15

1. Exemption Lists

- Division exemption lists
- Department-wide exemption list

Explain (which exemption list, which exemption, how it applies):

Covered under General exemptions contained in HAR §11-200.1-15 listed in #2 below

2. HAR §11-200.1-15 exemptions

- Operations, repairs, or maintenance of existing structures, facilities, equipment, or topographical features, involving *minor expansion or minor change of use* beyond that previously existing
- Replacement or reconstruction of existing structures and facilities where the new structure will be located generally on the same site and will have *substantially the same purpose, capacity, density, height, and dimensions* as the structure replaced
- Construction and location of single, new, small facilities or structures and the alteration and modification of the facilities or structures and installation of new, small equipment or facilities and the alteration and modification of the equipment or facilities, including, but not limited to:
  - (A) *Single family residences less than 3,500 square feet*, as measured by the controlling law under which the proposed action is being considered, if not in conjunction with the building of two or more such units;
  - (B) Multi-unit structures designed for *not more than four dwelling units* if not in conjunction with the building of two or more such structures;
  - (C) Stores, offices, and restaurants designed for total occupant load of *twenty persons or less* per structure, if not in conjunction with the building of two or more such structures; and
  - (D) Water, sewage, electrical, gas, telephone, and other essential public utility services extensions *to serve such structures* or facilities; accessory or appurtenant structures including garages, carports, patios, swimming pools, and fences; and acquisition of utility easements
- Minor alterations* in the conditions of land, water, or vegetation
- Basic data collection, research, experimental management, and resource and infrastructure testing and evaluation activities that *do not result in a serious or major disturbance* to an environmental resource
- Demolition of structures, *except* those structures that are listed on the national register or Hawaii Register of Historic Places

**Dam Safety Program  
CHAPTER 343 ANALYSIS**

- Zoning variances *except shoreline* set-back variances
- Continuing administrative activities;
- Acquisition of land and existing structures, including single or multi-unit dwelling units, for the provision of *affordable housing*, involving *no material change of use* beyond that previously existing, and for which the *legislature has appropriated or otherwise authorized funding*
- New construction of affordable housing, where affordable housing is defined by the controlling law applicable for the state or county proposing agency or approving agency, that meets the following: (A) Has the use of state or county lands or funds or is within Waikiki as the sole triggers for compliance with chapter 343, HRS; (B) As proposed conforms with the existing state urban land use classification; (C) As proposed is consistent with the existing county zoning classification that allows housing; and (D) As proposed does not require variances for shoreline setbacks or siting in an environmentally sensitive area, as stated in section 11-200 .1-13 (b) (11).

Explain (how the exemption indicated above applies):

This is a dam safety project. The existing embankment and dam appurtenances associated with the two reservoirs are no longer safe. The reservoirs currently do not contain water. Removal will allow natural drainage through the existing reservoir sites and reduce future risk associated with impounded water. Historic American Engineering Records (HAER) for Upper Anahola reservoir- HAER N. HI135 and Kealia No. 1 Reservoir- HAER No. HI-133 were completed and reviewed by State Historic Preservation Division (SHPD). The HAER mitigation commitments were accepted by SHPD in a letter dated January 23, 2017, Log #2016.02750, Doc#1701JLP16.

Exemptions summary:

Does the Project qualify for an exemption?    Yes X            No

If Yes, Exemption noted above, No Environmental Assessment required

If No, Project does not qualify for exemption and requires an Environmental Assessment

**CUMULATIVE IMPACT**

Exemptions are inapplicable when the cumulative impact of planned successive actions in the same place, over time, is significant, or when an action that is normally insignificant in its impact on the environment may be significant in a particularly sensitive environment.

**SUMMARY**

Is Environmental Assessment required?

Yes

Has an Environmental Assessment been completed?

Yes             OEQC Published date: \_\_\_\_\_

No X

**Dam Safety Program**  
**CHAPTER 343 ANALYSIS**

Comments: The project is located within the Kamalomalo'o Ahupua'a, in an area that is characterized by flat plateaus divided by streams and gulches. Both reservoirs were constructed in the early 1900's to support the cultivation of sugar cane in the surrounding land. Keālia Field 1 receives approximately 65 to 80 inches of rainfall per year. Upper Anahola receives less at approximately 50 inches annually. During the plantation days, the sugar cane fields mauka from the Keālia Landing Strip were mostly non-irrigated, while those makai were dependent on man-made irrigation canals. The reservoirs and dams in this project were most likely constructed to support the irrigation needs of the fields in the drier lower elevations.

The project site is located outside of any 3.2-foot sea-level-rise exposure area, special management area as well as areas identified as critical habitats for threatened, rare and/or endangered species. The reservoirs are identified as freshwater pond features by USFWS National Wetlands Inventory Maps (NWI) based on remote, ortho-imaging and are identified as Flood Hazard Area A (with a low flood risk). The project site is designated as Agriculture by the State Land Use Board. The project is located within DHHL's General Agriculture Land Use designation. The actions proposed are consistent with activities allowed on lands with these designations.

Since the purpose of the project is to reduce the capacity of the reservoirs by decommissioning the dams and allowing natural drainage, there is a corresponding reduction in the risk and vulnerability of a dam failure on the homes and properties located downstream thereby increasing the safety to residents, lessees and landowners.

Reviewer Printed Name: Malia Cox, NAHASDA Compliance Specialist

Reviewer Signature: 

**Concurrence with Chapter 343 Analysis**

The direct, cumulative, and potential impacts of the action described above have been considered pursuant to Chapter 343, Hawai'i Revised Statutes and Chapter 11-200.1, Hawai'i Administrative Rules. The Land Development Division's Decommissioning of Keālia Field 1 and Upper Anahola Reservoirs, Anahola, Kauai, are eligible for exemption from the environmental assessment process because the proposed actions are consistent with the listed actions in HAR Section 11-200.1. The action described above will have minimal or no significant impact on the environment and is therefore exempt from the requirement to prepare an environmental assessment.

  
William J. Aila, Jr., Chairman  
Hawaiian Homes Commission

Date: 8/31/22

**JOSH GREEN, M.D.**  
GOVERNOR | KE KIA'ĀINA

**SYLVIA LUKE**  
LIEUTENANT GOVERNOR | KA HOPE KIA'ĀINA



**STATE OF HAWAII | KA MOKU'ĀINA 'O HAWAI'I  
DEPARTMENT OF LAND AND NATURAL RESOURCES  
KA 'OIHANA KUMUWAIWAI 'ĀINA**

STATE HISTORIC PRESERVATION DIVISION  
KAKUHIHEWA BUILDING  
601 KAMOKILA BLVD, STE 555  
KAPOLEI, HAWAII 96707

**DAWN N.S. CHANG**  
CHAIRPERSON  
BOARD OF LAND AND NATURAL RESOURCES  
COMMISSION ON WATER RESOURCE MANAGEMENT

**LAURA H.E. KAAKUA**  
FIRST DEPUTY

**M. KALEO MANUEL**  
DEPUTY DIRECTOR - WATER

AQUATIC RESOURCES  
BOATING AND OCEAN RECREATION  
BUREAU OF CONVEYANCES  
COMMISSION ON WATER RESOURCE MANAGEMENT  
CONSERVATION AND COASTAL LANDS  
CONSERVATION AND RESOURCES ENFORCEMENT  
ENGINEERING  
FORESTRY AND WILDLIFE  
HISTORIC PRESERVATION  
KAHOOLAWE ISLAND RESERVE COMMISSION  
LAND  
STATE PARKS

March 30, 2023

Ikaika Anderson, Interim Chairman  
Hawaiian Homes Commission  
Department of Hawaiian Home Lands  
P.O. Box 1879  
Honolulu, HI 96805  
c/o Cornelius Nugent, Land Development Division  
cornelius.f.nugent@hawaii.gov

IN REPLY REFER TO:  
Project No. 2016PR22703  
Doc. No. 2303MA06  
Architecture,  
Archaeology

Dear Mr. Anderson:

**SUBJECT: HRS Chapter 6E-8 Historic Preservation Review –  
Decommission Kealia Field No. 1 Reservoir and Upper Anahola Reservoir  
Kamalomalo'ō Ahupua'a, Puna District, Island of Kaua'i  
TMK(s): (4) 4-7-002:004, (4) 4-7-004:002**

This letter provides the State Historic Preservation Division's (SHPD's) review of the proposed project titled *Decommission Kealia Field No. 1 Reservoir and Upper Anahola Reservoir*, which constitutes a change in the scope of work of the project titled *Repair and Replacement of DHHL Reservoirs in Anahola*, which SHPD consulted on from 2014 through 2016 (see Doc. Nos. 1410MN03, 1507MN18, 1610JLP02), and for which mitigations were completed as of 2017 (see Doc. No. 1701JLP16). A series of meetings between the Department of Hawaiian Home Lands (DHHL) and the SHPD were held between June 2022 and March 2023 to discuss the current change in scope of work for the project: from the decommissioning of two reservoirs and reconstruction of 2 reservoirs, to the decommissioning of all four reservoirs, including Kealia Field No. 1 and Upper Anahola, which were previously planned for repaired. Documents submitted for both the earlier and current scope of work can be found under Project Documents within HICRIS Project No. 2016PR22703.

The DHHL proposes to decommission Kealia Field No. 1 Reservoir and Upper Anahola Reservoir, both located on Hawaiian Home Lands land [TMKs (4) 4-7-002:004, (4) 4-7-004:002] in Kamalomalo'ō Ahupua'a, on the northern edge of the Puna District, in northeastern Kaua'i. The project area comprises 8.20 acres at the Upper Anahola Reservoir and 4.44 acres at the Kealia Field No. 1 Reservoir, for a total of 12.64 acres subject to ground disturbance in the form of grading that will remove the existing reservoir embankment and deposit the excavated fill material within the reservoir basin area as compacted fill. The intent is to restore the watershed flow to its natural condition. There is currently no water standing in either reservoir.

LYON produced a *Limited Archaeological & Historical Survey* in 2014 in support of the original Anahola Reservoirs Improvement Project, covering all four reservoirs. This report provided background information and preliminary documentation of historic properties within the project area, particularly the historic reservoirs themselves. A 2014 SHPD Review Letter recommended an Archaeological Inventory Survey be conducted. In 2015 the Kaua'i Lead Archaeologist at the SHPD conducted fieldwork within the project area to supplement existing data on historic property features and facilitate the HRS 6E historic preservation review process. As a result of ongoing concerns, and

Mr. Anderson  
March 30, 2023  
Page 2

in light of the nature of the historic properties in question, in 2015 the SHPD Architecture Branch requested Historic American Engineering Record (HAER) Level III documentation of tunnels and tunnel headwalls for all four reservoirs as a mitigation measure for the alteration of the historic reservoir features, which at the time included the decommissioning of two reservoirs and reconstruction of two reservoirs. Mason Architects produced HAER documentation for all four reservoirs, which the SHPD accepted in October 2016 and requested be submitted to the National Park Service. SHPD confirmed NPS acceptance of all four HAER (HI-133, HI-134, HI-135, and HI-136) in a letter dated January 23, 2017, marking the SHPD's final acceptance of HAER mitigation commitments for the original *Repair and Replacement of DHHL Reservoirs in Anahola* project. No State Inventory of Historic Places (SIHP) numbers were ever generated for these historic reservoirs, individually or as a single multicomponent historic property.

The SHPD agrees that the project area remains the same, and that the two reservoirs subject to the changed scope of work have been sufficiently documented in HAER Nos. HI-133 (Kealia Field No. 1) and HI-135 (Upper Anahola Reservoir). The **SHPD requests** that a State Inventory of Historic Places (SIHP) Request be made for a single multicomponent historic property, the Kealia Agricultural Water System, comprising the four reservoirs subject to HAER Level III documentation as part of mitigation for this project. Instructions on how to submit this SIHP Request can be found on the SHPD website (<https://dlnr.hawaii.gov/shpd/forms/>).

The **SHPD concurs** with a determination of Effect, with proposed mitigation commitments for *Decommission Kealia Field No. 1 Reservoir and Upper Anahola Reservoir*. Previous mitigation commitments have been met to the SHPD's standards (see Doc. Nos. 1610JLP02, 1701JLP16). The one outstanding mitigation commitment is the submission of the SIHP Request requested above.

The **SHPD looks forward to receiving** a SIHP Request in order to progress towards completion of the HRS 6E-8 Historic Preservation Review for *Decommission Kealia Field No. 1 Reservoir and Upper Anahola Reservoir*. Please submit any forthcoming information and correspondence related to the subject project to SHPD via HICRIS to Project No. 2016PR22703 using the Project Supplement option. These SIHP Requests can be completed concurrently with the commencing of proposed work to decommission the two subject reservoirs.

Please contact Jessica Puff, Architecture Branch Chief, at [Jessica.Puff@hawaii.gov](mailto:Jessica.Puff@hawaii.gov) for matters regarding architectural resources; and Susan A. Lebo, Archaeology Branch Chief, at [Susan.A.Lebo@hawaii.gov](mailto:Susan.A.Lebo@hawaii.gov) or Megan E. Alvarez, Historic Preservation Archaeologist IV, at [Megan.Alvarez@hawaii.gov](mailto:Megan.Alvarez@hawaii.gov) for matters regarding archaeological resources or this letter.

Aloha,

*Alan Downer*

Alan S. Downer, PhD  
Administrator, State Historic Preservation Division  
Deputy State Historic Preservation Officer

cc: Stewart Matsunaga, DHHL [stewart.t.matsunaga@hawaii.gov](mailto:stewart.t.matsunaga@hawaii.gov)  
Andrew Choy, DHHL [andrew.h.choy@hawaii.gov](mailto:andrew.h.choy@hawaii.gov)  
Malia Cox, DHHL [malia.m.cox@hawaii.gov](mailto:malia.m.cox@hawaii.gov)  
Bryan Toda, DHHL [bryan.toda@hawaii.gov](mailto:bryan.toda@hawaii.gov)  
Robert Ing, DHHL [robert.m.ing@hawaii.gov](mailto:robert.m.ing@hawaii.gov)  
Richard Speer, DHHL [richard.a.speer@hawaii.gov](mailto:richard.a.speer@hawaii.gov)  
Nancy McPherson, DHHL [Nancy.m.mcpherson@hawaii.gov](mailto:Nancy.m.mcpherson@hawaii.gov)  
Kaipo Duncan, DHHL [Kaipo.duncan@hawaii.gov](mailto:Kaipo.duncan@hawaii.gov)  
Niniau Kawaihae, DHHL [niniau.kawaihae@hawaii.gov](mailto:niniau.kawaihae@hawaii.gov)  
Michelle Inafuku, DHHL [michelle.m.inafuku@hawaii.gov](mailto:michelle.m.inafuku@hawaii.gov)  
Eric Tamashiro, Bowers + Kubota [etamashiro@bowersandkubota.com](mailto:etamashiro@bowersandkubota.com)  
Brian Bowers, Bowers + Kubota [bbowers@bowersandkubota.com](mailto:bbowers@bowersandkubota.com)

Permit #93  
 Field 1 Kealia Reservoir KA-0067  
 Removal  
**Agency Consultation:**

**Exhibit 6**

Agency	Date Sent	Date Returned	No Comments	Comments Attached	No Reply
<b>DLNR agencies</b>					
Division of Aquatic Resources	10/26/2023				X
Commission on Water Resources Management	10/26/2023	12/8/2023		X	
Division of Forestry and Wildlife	10/26/2023	12/7/2023		X	
Historic Preservation Division	2014-2016	3/30/2023		X	
Land Division	10/26/2023	10/27/2023	X		
Office of Conservation and Coastal Lands	10/26/2023				X
<b>Other Agencies</b>					
Department of Agriculture	10/26/2023				X
Department of Agriculture – ADC	10/26/2023				X
County of Kauai – NFIP	10/26/2023			Worked directly with applicant	
Kauai Emergency Management Agency	10/26/2023				X
HI EMA	10/26/2023				X



**DAM SAFETY PERMIT GENERAL CONDITIONS****APPROVAL OF PLANS AND SPECIFICATIONS FOR DAM AND RESERVOIR  
CONSTRUCTION, ENLARGEMENT, REPAIR, ALTERATION OR REMOVAL**

The following General Conditions shall be adhered to for all Dam Safety permits unless otherwise authorized in writing.

1. Actual construction, enlargement, repair, alteration or removal shall be completed within 5 years of issuance of the permit application approval unless an extension authorized in writing by the Board is issued.
2. Prior to the start of work the owner or applicant shall provide a construction engineer to ensure compliance with the approved plans and specifications and who shall have ultimate responsibility for the supervision of all inspection tasks. The construction engineer may assign some inspection tasks to a duly authorized agent under the construction engineer's supervision. The engineer shall be licensed in the State of Hawaii.
3. The construction engineer shall maintain a record of construction that at a minimum, shall include, daily activity, and progress reports, all test results pertaining to construction; photographs sufficient to provide a record of foundation conditions and various stages of the construction through completion, all geologic information obtained; and construction problems and remedies.
4. A construction quality assurance plan shall be prepared and submitted to the Department for approval prior to the start of construction, which details the minimum requirements of the construction engineer's observation of construction.
5. A construction schedule, which includes the notice to proceed date and estimated project duration and a construction emergency action plan shall be submitted prior to the preconstruction meeting.
6. A preconstruction meeting shall be held subsequent to submitting the quality assurance plan, construction schedule and construction emergency action plan, but not later than 14 days prior to the start of construction. All parties actively involved in the construction should be requested to attend, such as the dam owner, the design engineer, the construction engineer, the contractor and the Department.
7. The Department shall be notified 5 calendar days prior to the commencement of construction.
8. Any changes from the approved plans and specifications shall be approved by the design engineer and a change order, including details and supporting calculations, must be provided to the Department. Major changes must be submitted in writing with supporting documentation and approved in writing by the Department. No work shall be initiated until the approval by the Department or Board is received. Minor changes may be transmitted verbally and approved by the Department verbally provided that documentation of the change is provided to the Department within 10 days of the approval.



9. For new dam construction and for dams and reservoirs that have lowered the water level or have been drained to facilitate construction, the construction engineer shall file and obtain approval of a filling plan with the Department. The applicant/owner shall not proceed with the filling of the reservoir until it receives permission from the Department. The construction engineer shall provide documentation of monitoring during the filling operation.
10. Prior to the filling of the reservoir, the construction engineer shall submit one copy each of the approved Operations Manual and the approved Emergency Action Plan for the facility upon completion of the project as applicable.
11. The construction engineer shall give the Department at least ten days advanced notice of initial materials placement of the dam's foundation, in the cutoff trench, outlet backfill, outlet foundation, and any appurtenance requested by the Department in the approval of the plan for construction observation, to allow for observation by the Department.
12. Notice of substantial completion shall be issued by the construction engineer to the Department stating that the permitted improvements are functionally complete such that filling of the reservoir can be initiated with an approved filling plan.
13. The construction engineer shall give the Department fifteen (15) calendar days advance written notice prior to the project's final construction inspection. The construction engineer shall coordinate with the Department to conduct this inspection in the presence of the Department's dam safety personnel.
14. The construction engineer shall provide notice at least ten (10) days prior to initiating filling the reservoir, unless agreed at the final inspection.
15. If conditions are revealed which will not permit the construction, enlargement, repair, alteration, or removal of a safe dam or reservoir, the application for approval for construction, enlargement, repair, alteration, or removal shall be revoked.
16. A topographic survey of completed work including all monuments, inverts, crest alignment, spillways, and significant appurtenant features, when required by the Department shall be completed.
17. The applicant/owner shall utilize appropriate erosion control best management practice measures during construction to minimize turbidity (such as scheduling of work during period of low stream flow) and prevent debris and construction materials, including concrete, petroleum products, and other pollutants from enter the waters of the State. Construction related water and debris should be properly disposed of in a legal and environmentally safe manner and in accordance with the Department of Health and other Federal regulations.
18. The applicant/owner shall submit a copy of the dam safety application and the plans and specifications of the proposed improvements to the County Engineer of the County for which the dam resides for compliance with County codes.
19. Within fifteen (15) calendar days of completing the project, the applicant/owner or its representative shall provide the Department with a confirmation letter of compliance, signed and stamped by the construction engineer, indicating that the construction

was completed in accordance to approved plans and specifications including any field changes. The construction engineer shall submit the remaining construction completion documents which may include, but not be limited to, as-constructed drawing, final construction report, topographic survey, record of the location of permanent monuments, log of recorded water levels and other readings from the refilling operation, long-term instrumentation monitoring plan, and affidavit showing the actual cost of construction including engineering costs, within 60 calendar days of the submittal of the final construction inspection.

20. Construction completion documents and the construction engineer's certification shall be provided to the Department within 60 days of the final construction inspection. The Department will review the submitted items and furnish acceptance or denial within 60 days of receipt of satisfactorily completed construction completion documents and close out the dam safety permit.
21. This permit does not relieve the applicant/owner of their obligations to comply with all applicable Federal, State, and County regulations.
22. In the unlikely event that subsurface historic resources, including human skeletal remains, structural remains, cultural deposits, artifacts, sand deposits, or sink holes are identified during the demolition and/or construction work, cease work in the immediate vicinity of the find, protect the find from additional disturbance, and contact the State Historic Preservation Division at (808) 692-8015.
23. Compliance with Hawaii Revised Statutes 179D, and Hawaii Administrative Rules 13-190.1.